



IIT PALAKKAD

Indian Institute of Technology Palakkad
भारतीय प्रौद्योगिकी संस्थान पालक्काड

Nurturing Minds For a Better World

Tender No. 17/ IITPKD/EWD/2022-23/009

Indian Institute of Technology Palakkad Invites Notice Inviting Bid under Two-bid system (through ONLINE Mode) for the below mentioned work:

NAME OF WORK: CONSTRUCTION OF PERMANENT CAMPUS FOR IIT PALAKKAD UNDER PHASE 1A SH: FURNITURE SW: SUPPLY AND INSTALLATION OF SINGLE SEATER FLAP TYPE CHAIR FOR CLASSROOMS IN A01, B03, B04 AT MAIN CAMPUS

S. No.	Events	Date and Time
1	Notice Inviting BID (NIT) No.	17/ IITPKD/EWD/2022-23/009
2	Date of Publication	07-09-2022, 1500 hrs
3	Date / Time of closing	28-09-2022, 1500 hrs
4	Date / Time of submission of sample furniture	23-09-2022, 1500 hrs
5	Date of Pre bid Meeting (Thro' VC)	13-09-2022, 1100 hrs
6	Opening of Technical cum eligibility Bids	28-09-2022, 1530 hrs
7	Estimated Cost put to bid	Rs.1,35,00,000/-
8	Earnest Money Deposit (EMD)	Rs. 2,70,000/-

INDEX

SI No	Description	Page No
1	GENERAL	3
2	AMENDMENTS IN THE TENDER DOCUMENT	3-4
3	COMPOSITION OF THE TENDER DOCUMENT (TECHNICAL CUM ELIGIBILITY BID)	4
4	EARNEST MONEY DEPOSIT (EMD)	4
5	LANGUAGE/FORMAT/SIGNING OF THE BID	5
6	METHOD OF SUBMISSION OF BID	5
7	BID PRICES	5
8	CONFORMITY OF THE TENDER DOCUMENT	6
9	PERIOD OF VALIDITY OF BIDS	6
10	MODIFICATION AND WITHDRAWAL OF BIDS	6
11	OPENING AND EXAMINATION OF BIDS	6
12	CLARIFICATION OF BIDS	6
13	CONTACTING IITPKD	7
14	AWARD CRITERIA	7
15	IITPKD RIGHT TO ACCEPT/REJECT BIDS	7
16	AWARD OF PURCHASE ORDER	8
17	CONTRACT AGREEMENT	8
18	CONTRACT DOCUMENTS	9
19	AMENDMENT TO CONTRACT	9
20	SUPPLIER'S RESPONSIBILITIES	9
21	TIME FOR SUPPLY, INSTALLATION, COMMISSIONING AND VALIDATION OF THE FURNITURE	10
22	TERMS OF PAYMENT	10
23	TAXES AND DUTIES	11

24	MAINTENANCE DURING WARRANTY PERIOD	11
25	PENALTIES	11
26	INTELLECTUAL PROPERTY RIGHTS AND WARRANTY AND INDEMNITY	11
27	EXTENSION OF TIME LIMITS FOR SUPPLY AND MAKING OPERATIONAL, THE FURNITURE	12
28	GOVERNING LAW	12
29	SETTLEMENT OF DISPUTES	12
30	ANNEXURE - I	13-14
31	ANNEXURE 1A & 1B	15-21
32	ANNEXURE II	22
33	ANNEXURE III	23
34	ANNEXURE IV	24
35	ANNEXURE V	25
36	ANNEXURE VI	26
37	ANNEXURE VII	27
38	ANNEXURE VIII	28

1. GENERAL

- 1.1. Indian Institute of Technology Palakkad (hereinafter called "IITPKD") invites online tenders under Two-Bid System (Eligibility cum technical and Financial bid) as per the technical specifications given in **Annexure-I**.
- 1.2. The tender document can be accessed from <https://mhrd.euniwizarde.com/>. Last date/time for submission of the bids in **ONLINE mode** is **28-09-2022 1500 hours**. The bids will be opened through online mode. **The technical cum eligibility bids will be opened first and the bid will be decided for the satisfying the eligibility criteria as per tender conditions**. Only those who qualify in the technical evaluation will be qualified for opening of financial bids. In case of any holiday or unforeseen closure of the institute on the scheduled day of opening of the bids, the bids will be opened on the next working day at the same time, but the deadline for submission of bids remains the same as indicated above.
- 1.3. The bids should be submitted **ONLY** through online mode at <https://mhrd.euniwizarde.com/> latest by **28-09-2022 1500 hours**. Bids received after the above-mentioned date and time will not be considered. Conditional bids will be rejected outright.
- 1.4. The responsibility of submission of the bids on or before the last date shall rest with the tenderer. The institute will hold no responsibility for the non-receipt of the bids or for the bids received after the date/time specified. Any bid received by IITPKD after the bid submission deadline prescribed by IITPKD, shall be rejected and returned unopened to the Bidder.
- 1.5. Canvassing or offering of an advantage or any other inducement by any person with a view to influencing acceptance of a bid is an offense under Laws of India. Such action will result in the rejection of the bid, in addition to other punitive measures.
- 1.6. Each bidder shall submit only one bid, either by himself or as a partner in a joint venture or as a member of a consortium. If a bidder or if any of the partners in a joint venture or any one of the members of the consortium participate in more than one bid, the bids (of both the individual and the partnership/consortium) are liable to be rejected.
- 1.7. Joint ventures are not eligible.
- 1.8. The bidder shall bear all costs associated with the preparation and submission of his bid and IITPKD shall in no case be responsible or liable for those costs, regardless of the conduct or outcome of the tender process.
- 1.9. IITPKD will respond to any request for clarification or modification of the Tender Document that is received up to TWO DAYS prior to the deadline for submission of bids prescribed by IITPKD. For this purpose, the prospective bidder(s) requiring clarification in the Tender Document shall notify IITPKD through the ONLINE Portal ONLY. Any such clarification, together with all details on which the clarification had been sought, will be published in the ONLINE Portal ONLY.
- 1.10. Except for any such clarification by the Institute, which is expressly stated to be an addendum to the tender document issued by the **Chairman, EWD, IIT Palakkad**, no written or oral communication, presentation or explanation by any other employee of any of the Sections/Departments of the Institute, shall be taken to bind or fetter the Institute.
- 1.11. **Pre bid Meeting: Online Pre-bid meeting will be held on 13-09-2022 at 1100 hours to clear the doubts of intending bidders. The details of the meeting will be intimated through the ONLINE Portal. Bidders, who are unable to attend the Pre-bid Meeting may send their queries for the same, latest by 12-09-2022 hours of 1700hrs to ewd@iitpkd.ac.in. Queries received after the Pre-bid Meeting shall not be considered. Addendum/Corrigendum/Clarifications to the Queries will be uploaded, post the Pre-bid Meeting in the ONLINE Portal, which shall be the part of the Tender Document. The bidders may visit the campus to have more clarity about the site and buildings.**

2. AMENDMENTS IN THE TENDER DOCUMENT

- 2.1. At any time prior to the deadline for submission of bids, IITPKD may, for any reason, whether at its own initiative or in response to a clarification requested by a prospective Bidder, modify the Tender Document by way of amendment(s).
- 2.2. Amendments will be intimated through the e-wizard Portal and the bidders shall ensure that the amendments are carried out in the bid before submission. The amendments will not be published in newspapers. Bidders should regularly visit e-wizard Portal to keep themselves updated.
- 2.3. No extension in the bid due date/ time shall be considered on account of delay in receipt of any document by mail. Further, it will be assumed that the Bidder has taken into account such amendments, while submitting the bid.

3. COMPOSITION OF THE TENDER DOCUMENT (TECHNICAL CUM ELIGIBILITY BID)

- 3.1. The Tender Document comprises of:

Cover 1 : Eligibility Bid cum Technical Bid

- (a) Technical Specifications (Annexure-I)
 - (b) Drawing (Annexure IA)
 - (c) Furniture Unloading location (Annexure IB)
 - (d) Pre-qualification Criteria (Annexure-II)
 - (e) Techno- financial Parameters (Annexure-III)
 - (f) Compliance Statement (Annexure-IV)
 - (g) Declaration (Annexure-V)
 - (h) Fall Clause Notice Certificate (Annexure-VI)
 - (i) Declaration for make in India (Annexure-VII)
 - (j) Acknowledgement of sample issued by executive engineer,EWD,IITPKD (Annexure VIII)
- 3.2. The bidder is expected to examine all instructions, forms, terms and conditions in the Tender Document. In the event of discovery of any missing pages, the bidder shall inform the same to the Section/ Department concerned. Failure to furnish the information required by the Tender Document or submission of a tender not substantially responsive to the Tender Document in every respect will be at the bidder's risk and may result in rejection of the bid.
 - 3.3. The bidder shall not make or cause to be made any alteration, erasure or obliteration to the text of the Tender Document.
 - 3.4. Financial bid (Cover 2) shall be downloaded from the E-wizard portal and fill the commercial bid and upload.

4. EARNEST MONEY DEPOSIT (EMD)

- 4.1. The bidder shall furnish **EMD of Rs. 2,70,000/- (Rupees Two Lakh Seventy Thousand Only) through online payment gateway in the E-Wizard.**
- 4.2. Bids not accompanied by EMD shall be DISQUALIFIED
- 4.3. EMD of the successful bidder shall be returned on receipt of the prescribed Performance Security and after signing of the contract agreement.
- 4.4. EMD of the unsuccessful bidders will be returned to them at the earliest after expiry of the final bid validity and latest by the 30th day after the award of the contract.
- 4.5. EMD shall be forfeited
 - a. if the bidder withdraws his bid during the period of validity of the tender.
 - b. if the successful bidder refuses or neglects to execute the contract or fails to furnish the required Performance Security within the time frame specified by the Institute.
 - c. if the successful bidder fails to execute the Contract on specified timeline
- 4.6. **The firms who are registered with National Small Industries Corporation (NSIC) / or Small Scale Industrial (SSI)/ Micro & Small Enterprises (MSEs) are exempted from furnishing the**

EMD. Self-attested photocopy of valid registration certificate issued by competent authority for supply of "Furniture & Fittings, wooden Carpentry and fitting works, Steel furniture's and fittings works' ' to be uploaded with the technical bid for exemption of EMD.

5. LANGUAGE/FORMAT/SIGNING OF THE BID

- 5.1. The bid prepared by the Bidder and all correspondence and documents related to the tender exchanged by the Bidder and IITPKD shall be in English and the Contract shall be construed and interpreted in accordance with that language. If any of the brochures, leaflets or communication is prepared in any language other than English, a translation of such document, correspondence or communication shall also be provided at the cost and risk of the bidder. The translation so provided shall prevail in matters of interpretation. The bidder, with respect to such documents, correspondence and communications, shall bear the costs and risks of such translation.
- 5.2. The documents comprising the bid shall be typed or written in indelible ink and all the pages shall be signed by the bidder or a person or persons authorized by the bidder. All the pages of the bid shall be numbered and except for unamendable printed, shall be signed by the person or persons authorized and uploaded.
- 5.3. The bid shall not contain any internalizations, erasures, overwriting, except to correct errors made by the bidder, in which case the person or persons signing the bid shall initial such corrections with date.

6. METHOD OF SUBMISSION OF BID

- 6.1. The Technical bid (Cover 1) and the Financial Bids (Cover 2) shall be submitted ONLINE through the portal mentioned as Cover One and Cover Two.
- 6.2. Bids submitted in any mode other than ONLINE will be rejected outright.
 - (a) **Bids without furnishing EMD through online mode and without submission of sample furniture shall be DISQUALIFIED.**
- 6.3. Original Catalog (not any photocopy) of the quoted model duly signed by the authorized signatory must be uploaded in the technical bid.
- 6.4. No prices should be entered in the technical bid. Mentioning of Prices in the Technical Bid shall lead to disqualification
- 6.5. Compliance or Confirmation report with reference to the specifications and other terms and conditions should also be obtained from the principal.
- 6.6. Information related to the agency/bidder such as photocopies of the Registration/ PAN/ GST/ TIN shall be furnished.
- 6.7. The technical bid should consist of all technical details along with financial terms and conditions.
- 6.8. Digitally signed tender documents should be uploaded in Cover One.
- 6.9. The bidder must provide a Sample of Furniture at IIT Palakkad, on or before . The financial bids will be opened only by those firms, whose eligibility cum technical bid and sample furniture satisfies the criteria given in the technical bid.

7. BID PRICES

- 7.1. Prices must be quoted separately for each item of Furniture as given in the Annexure 1
BID CURRENCY
- 7.2. Prices of indigenous Furniture/items shall be quoted in Indian Rupees.

8. CONFORMITY OF THE TENDER DOCUMENT

- 8.1. The Bidder shall furnish, in terms of Technical Specifications are given in the Tender document.

9. PERIOD OF VALIDITY OF BIDS

- 9.1. Bids shall remain valid for a period of 90 days after the date of deadline for submission of bids prescribed by the Purchaser.

10. MODIFICATION AND WITHDRAWAL OF BIDS

- 10.1. The Bidder may modify or withdraw the bid after submission only through ONLINE mode, within the period of deadline for submission of bids.
- 10.2. No bids can be modified subsequent to the deadline for submission of Bids.
- 10.3. No bids can be withdrawn in the interval between the bid submission deadline and the expiration of the bid validity period. Withdrawal of a bid during this interval may result in the forfeiture of the Bidder's SD.

11. OPENING AND EXAMINATION OF BIDS

- 11.1. The Technical bids will be opened on the prescribed date and time as mentioned in the Bid document in ONLINE mode.
- 11.2. The accepting authority will evaluate the technical bids along with samples for the conformity with the eligibility criteria. Those bids, whose technical bids fulfill the technical requirements and conformity with the eligibility criteria and responsive to the tender requirements will be considered for opening of financial bids. Those bids which are found to be either non-responsive, not satisfying the technical requirements will not be considered and will be rejected.
- 11.3. The financial bids of the eligible bidders on the basis of evaluation as mentioned in 11.2 above will be opened on the date which will be intimated later.
- 11.4. Arithmetical errors will be rectified on the following basis. If there is a discrepancy between the unit price and the total price, which is obtained by multiplying the unit price and quantity, or between subtotals and the total price, the unit or subtotal price shall prevail and the total price shall be corrected. If there is a discrepancy between words and figures, the amount in words shall prevail. If a Bidder does not accept the correction of errors, the bid will be rejected and its Security Deposit may be forfeited.
- 11.5. The Purchaser may waive any minor non-conformity or irregularity in a bid that does not constitute a material deviation, provided such waiver does not prejudice or affect the relative ranking of any Bidder.
- 11.6. If a bid is not substantially responsive, it shall be rejected by the Purchaser and may not subsequently be made responsive by the Bidder by correction of the non-conformity.
- 11.7. The Purchaser's determination of bid responsiveness will be based on the contents of the bid itself and any written clarifications submitted by the Bidder.

12. CLARIFICATION OF BIDS

- 12.1. During the bid evaluation, the Purchaser may, at its discretion, ask the Bidder for a clarification of its bid. The request for clarification and the response shall be through ONLINE mode ONLY and no change in the price or substance of the bid shall be sought, offered or permitted.

13. CONTACTING IITPKD

- 13.1. From the time of bid opening to the time of Contract award, if any Bidder wishes to contact the Purchaser on any matter related to the bid, it shall do so through ONLINE mode ONLY.
- 13.2. If a Bidder tries to directly influence IITPKD or otherwise interfere in the bid evaluation process and the Contract award decision, his bid shall be rejected.

13.3. PERFORMANCE SECURITY

- 13.3.1. The performance security shall be submitted within **TEN (10) DAYS** of receipt of the material by the purchaser. The successful bidder shall furnish the **Performance Security equal to 3%** of the order / contract value (excluding the value of annual maintenance charges). The Performance Security shall be valid all along the warranty Period and shall extend up to SIXTY (60) DAYS after the date of completion of warranty period.

- 13.3.2. The performance security shall be a bank guarantee (in the format as provided in **Annexure-VI** of the bidding documents) issued by the Indian Scheduled bank acceptable to the Purchaser or a Demand Draft favoring, **INDIAN INSTITUTE OF TECHNOLOGY PALAKKAD** payable at PALAKKAD.
- 13.3.3. The performance security shall automatically become null and void once all the obligations of the Supplier under the Contract have been fulfilled, including, but not limited to, any obligations during the Warranty Period and any extensions to the period. The performance security shall be returned to the Supplier not later than **fifteen (15) days** after its expiration.
- 13.3.4. Failure of the successful Bidder to comply with the requirements shall constitute enough grounds for the annulment of the award and forfeiture of the EMD, in which event the Purchaser may make the award to the next lowest evaluated bid submitted by a qualified Bidder or call for new bids.

14. AWARD CRITERIA

- 14.1. IITPKD will award the Contract to the Bidder, whose bid has been determined to be substantially responsive and evaluated as the lowest quote.
- 14.2. IITPKD will award the Contract to the Bidder whose bid has been determined to be substantially responsive and as per the Order No. 45021/2/2017-PP(BE-II) dated 04-06-2020 from Department for Promotion of Industry and Internal Trade (Public Procurement Section), Ministry of Commerce and Industry, Govt. of India. 2. The Institute reserves the right to buy different items/quantities from different bidders considering price of individual/group of equipment/items or any other factors as decided by the Committee. The bidder should be a Class-I / Class-II Local Supplier meeting the requirement of minimum 20% Local Content in line with the Public Procurement (Preference to Make in India) Order 2017 No. P-45021/2/2017-PP (BE-II) dated 04 Jun 2020. The bidder is required to upload the undertaking given in **Annexure VII**.

15. IITPKD RIGHT TO ACCEPT/REJECT BIDS

- 15.1. IITPKD reserves the right to accept or reject any bid or to annul the bidding process and reject all bids at any time prior to Contract award, without thereby incurring any liability to the Bidders.
- 15.2. IITPKD reserves the right to negotiate with the Bidder, whose bid has been evaluated as the lowest quote.

16. AWARD OF PURCHASE ORDER

- 16.1. Prior to the expiration of the period of bid validity, IITPKD will issue the Letter of Intent / Purchase Order to the successful Bidder in writing.
- 16.2. The Purchase/Work Order will form the part of the Contract.

16.3. Submission of Samples:

a) During the submission of bid:

1. The bidder must provide Sample of Furniture at IIT Palakkad, on or before the date of opening of Technical Bids (Cover 1). The financial bids will be opened only by those firms, whose technical bid and sample satisfies the criteria given in the technical bid.
2. All samples submitted must be clearly labeled with the bidder name and address.
3. IITPKD will not be responsible for any damages to the Samples during its transit. In case any damages are observed, the contractor has to do proper finishing /replacing the unit without any extra cost to the Institute.

b) After award of the work:

1. The Bidder should supply samples of each item conforming to the technical specification given in Annexure – I for the approval of Chairman, EWD before commencement of bulk supply.
2. All the samples required for the test shall be supplied by the supplier free of cost. Where the samples which are supplied free are rejected after examination and test, the same of whatever remains of sample after examination and test will be

returned to the bidder at his cost on request made within one month of the date of rejection.

3. Factory Visit : Before issuing the purchase order, a specially formed committee may inspect the Manufacturing facility of the bidder to satisfy the capability of supplying the furniture. The committee's decision will be considered as final.
4. The samples shall be delivered in **EWD office, Main Campus, IIT Palakkad , Near Gramalakshmi Mudralayam, Kanjikode, Palakkad – 678 623** with an advance intimation to the EWD Office.
5. IITPKD will not be responsible for any damages to the Samples during its transit. In case any damages are observed, the contractor has to do proper finishing /replacing the unit without any extra cost to the Institute.
6. The contractor Should supply the chairs at the designated place as directed by the Engineer in charge as mentioned in the layout annexure IB. No extra claims will be entertained for loading, unloading and transportation if any are required to do the same.
7. Before shipment of bulk supply, the supplier shall ensure that the same quality as the given sample is maintained. The Engineer in Charge may inspect the goods at the firm's premises, before the supply is affected. In case the product deviates from the sample approved the Institute has rights to reject the same on arrival and the bidder has to remove the rejected items and replace them with items as per the specification given in the bid elsewhere.

- 16.4. **The Institute reserves the right to buy different items/quantities from different bidders considering price of individual/group of furniture or any other factors as decided by the Institute.**

17. CONTRACT AGREEMENT

- 17.1. Within **SEVEN (07) DAYS** of receipt of the Purchase/Work Order, the successful Bidder shall sign and date its copy on each page and return it to the Purchaser.
- 17.2. Copy of Purchase/Work Order duly signed and dated by the successful Bidder on each page shall constitute the Contract Agreement.

18. CONTRACT DOCUMENTS

- 18.1. All documents forming part of the Contract (and all parts of these documents) are intended to be correlative, complementary and mutually explanatory. The Contract shall be read as a whole.
- 18.2. The order of precedence of the Contract documents shall be as follows:
 - (i) Contract Agreement/Purchase Order
 - (i) All Forms/Annexures
 - (ii) Supplier's Bid
 - (iii) Tender Document
 - (iv) Catalog of the Furniture

19. AMENDMENT TO CONTRACT

- 19.1. No amendment or other variation of the Contract shall be effective unless it is in writing, is dated, expressly refers to the Contract and is signed by a duly authorized representative of each party to the Contract.

20. SUPPLIER'S RESPONSIBILITIES

- 20.1. The Supplier's obligations involve:
 - (a) Supply of furniture as per the specifications given in Tender Document in Annexure 1 and as per drawing.
 - (a) Making the furniture operational (installation, placing, positioning and making operational)
 - (b) Manufacturer warranty certificate
 - (c) Within warranty period if any onsite technical support as and when required.

- 20.2. The Supplier shall, unless specifically excluded in the Contract, perform all such work and/or supply all such items, services and materials not specifically mentioned in the Contract but that can be reasonably inferred from the Contract as being required for **supply installation, placing, positioning**, and making operational of Furniture as if such work and/or items and materials were expressly mentioned in the Contract.
- 20.3. The Supplier shall comply with all laws in force in India. The laws will include all national, provincial, municipal or other laws that affect the performance of the Contract and are binding upon the Supplier. The Supplier shall indemnify and hold harmless, the Purchaser from and against any and all liabilities, damages, claims, fines, penalties and expenses of whatever nature, arising or resulting from the violation of such laws by the Supplier.
- 20.4. If during the warranty Period any malfunctioning is experienced by the user in the Furniture, the Supplier shall promptly, at its sole cost, fix the issue. Necessary upgrades for the Furniture shall be provided by the Supplier on a regular basis during the warranty Period.
- 20.5. Response time for attending to malfunctioning reports shall be 24 to 48 hours, after they are reported to the Supplier or its designated service agent.

21. TIME FOR SUPPLY, INSTALLATION, COMMISSIONING AND VALIDATION OF THE FURNITURE

- 21.1. The Supplier shall supply the furniture within the period specified in the tender document i.e. **within 90 days** issuance of the purchase order or within the period mutually agreed between purchaser and supplier.
- 21.2. The Supplier shall thereafter proceed with the installation, commissioning, integration and validation and demonstrate operational acceptance of the furniture within the period specified. The furniture shall be installed and commissioned by the successful bidder within 20 to 25 days from the date of its receipt.
- 21.3. The tenderer should indicate clearly the time required for delivery of the item. In case there is any deviation in the delivery schedule, liquidated damages clause will be enforced or penalty for the delayed supply period will be levied.
- 21.4. In the event of failure of supply of the item/furniture within the stipulated delivery schedule, the Purchaser has all the right to purchase the item/furniture from other sources on the total risk of the Supplier under the risk purchase clause.
- 21.5. The furniture should be delivered inside the classroom as mentioned in the details of Annexure1B without any additional cost. Institute will not entertain any additional expenses on account doing the same.

22. TERMS OF PAYMENT

22.1 Schedule of Stage wise payment :

No advance payment shall be made. Payment shall be made as per stages given below

SL No	Stages of Payment	Individual	Cumulative % of payment
1	On satisfactory completion of supply and installation of classroom furniture of 300 Nos	30%	30% of contract value
2	On satisfactory completion of supply and installation of classroom furniture of 600 Nos	30%	60% of contract value
3	On satisfactory completion of supply and installation of whole classroom furniture and certified by the Engineer in charge	40%	100% of contract value
4	Security Deposit	3%	On completion of defect

			liability period
--	--	--	------------------

Note :

- a. Statutory deductions (TDS @ 2% will be deducted as per CBEC Circular No.65/39/2018-DOR, dated 14.09.2018)
- b. **GST or any other tax applicable in respect of inputs procured by the contractor for the contract shall be payable by the contractor and Institute will not entertain any claim whatsoever in respect of the same. However, component of GST at time of supply of service (as provided in CGST ACT 2017) provided by the contract shall be varied if different from that applicable on the last date of receipt of tender including extension if any**
- c. Security Deposit (SD) at the rate of 3% shall be made from the above mentioned schedule of payment

22.2 If any time before the delivery of the furniture, it is found that the same furniture had been offered to another party in India at a lower rate, payment shall be restricted to the extent of such lower rate and the Supplier shall be liable to pay the Purchaser the difference in two rates i.e. excess charged over such lower rate, if payment had been made by the purchaser. The purchaser will look into a reasonable past period to ensure this.

Installation Certificate in Original is essential for making the final payment/part payment. The successful bidder shall ensure that the installation and commissioning is done on time and produce the Installation Certificate in Original on time to the Engineering works Division.

23. TAXES AND DUTIES

- 23.1. The Supplier should ensure payment of all taxes, duties, levies and charges assessed by all municipal, state or national government authorities, in connection with the Goods and Services supplied under the Contract.
- 23.2. The quoted price should be inclusive of all taxes and other charges.

24. MAINTENANCE DURING WARRANTY PERIOD:

- 24.1. The supplier shall continue to support and maintain the furniture supplied by carrying out maintenance or minor repairs at the premises of the purchaser at free of cost during the warranty period.

25. PENALTIES

- 25.1. If the Supplier fails to complete any of the activities in accordance with the time specified for it, or any extension of the time granted by the Purchaser, the Supplier shall pay to the Purchaser, penalties at the rate of 1% per week not exceeding 5% of the contract value.
- 25.2. The Purchaser reserves the right to terminate the contract if the Supplier defaults on any of the time limits by more than FOUR weeks.

26. INTELLECTUAL PROPERTY RIGHTS AND WARRANTY AND INDEMNITY

- 26.1. The Supplier hereby represents and warrants that the as supplied, installed and commissioned along with its application furniture and copying of manuals and other documents provided to the Purchaser in accordance with the Contract does not and shall not infringe any Intellectual Property Rights held by any third party
- 26.2. **WARRANTY PERIOD** : The bidder should upload undertaking mentioning clearly the warranty period of **THREE YEARS** for furniture.
- 26.3. Security deposit at the rate of 3% of contract amount will be withheld and amount will be released only after completion of defect liability period
- 26.4. The warranty period shall commence from the date of validation/installation of the furniture and shall extend for the length of time specified in the tender document elsewhere.

- 26.5. The Supplier shall indemnify and hold harmless the Purchaser from and against any and/or all losses, liabilities and costs (including losses, liabilities and costs incurred in defending a claim alleging such a liability), that the Purchaser may suffer because of any infringement or alleged infringement of any Intellectual Property Rights.
- 26.6. **Defect Liability Period:** The Defect Liability Period for the work shall be **THREE YEARS** for all the furniture items from the date of installation.
- 26.7. **Liquidated Damages:** If the contractor fails to complete the supply of furniture on or before the stipulated date of completion or extended date of extension by the competent authority, pay as compensation the amount calculated at the rate stipulated below.
- 26.8. **Compensation for Delay**
- a. At the rate of 1% of the value of the undelivered goods per month or part thereof, subject to a maximum of 5% of the value of the undelivered goods.
 - b. It will also be open to the Institute alternatively, to arrange procurement of the required stores from any source, at the risk and expense of the firm, accepted and failed to execute the order according to stipulations agreed upon.
 - c. This will also entail debarring the supplier for future tender participation in IIT Palakkad.

27. EXTENSION OF TIME LIMITS FOR SUPPLY AND MAKING OPERATIONAL, THE FURNITURE

- 27.1. The time limit for supply, installation and commissioning, integration and validation shall be extended if the supply is delayed or impeded in the performance of any of its obligations under the Contract due to justified reasons and not otherwise. Such time limit shall be fair and reasonable under all the circumstances and shall fairly reflect the delay or impediment sustained by the Supplier.

28. GOVERNING LAW

- 28.1. The Contract shall be governed by and interpreted in accordance with the laws of India.

29. SETTLEMENT OF DISPUTES

- 29.1. Any dispute or claim arising out of/relating to this Contract of the breach, termination or the invalidity thereof, shall be settled by the Honorable Courts of Justice at Palakkad, Kerala.

31. The page number should be marked in all pages serially (including all supporting documents enclosed with the tender document) and the declaration for the same shall be submitted by the bidder as in **Annexure-VII**.

32. IITPKD reserves the right to accept or reject any or all the bids in part or whole or may cancel the tender at its sole discretion without assigning any reason whatsoever. No further correspondence in this regard will be entertained.

CHAIRMAN, EWD

TECHNICAL SPECIFICATIONS

NAME OF WORK: CONSTRUCTION OF PERMANENT CAMPUS FOR IIT PALAKKAD UNDER PHASE 1A SH: FURNITURE SW: SUPPLY AND INSTALLATION OF SINGLE SEATER FLAP TYPE CHAIR FOR CLASSROOMS IN A01, B03, B04 AT MAIN CAMPUS			
Item no	Description of items	Quantity	Unit
1	Supply and installation of Single Seater Flap type Chair for classroom as per the specification and sizes given below (refer to drawing no IITPKD/EWD/CLASSROOM /FURNITURE/02-Annexure 1A_)	975	nos
	Chair type:- Writing pad on one side		
	Type of seat and backrest:-19 mm thick molded hot compressed boiled water resistant plywood glued with PU coated high quality veneers		
	Frame material:		
	For seat and leg:-30 mm x30 mm, wall thickness 1.6 mm thick CRCA hollow tube		
	Base for leg-550 mm long x 30x 30x 1.60 mm thick CRCA hollow tube		
	Frame for back rest- 2 Nos elliptical shape 38 x 15 x 1.6 mm thick CRCA hollow section		
	Frame for under seat storage:Mild steel :-30 mm x 30 mm wall thickness 2.9 mm powder coated		
	Mesh for storage - 6 mm dia MS rod for 4 nos Horizontal & 11 nos vertical		
	Height of seat :- 430 mm from floor to middle of chair		
	Width of seat :- 440 mm		
	Overall chair height in mm :- 910 mm		
	Material of backrest - 19 mm thick hot compressed boiled water resistant plywood glued with PU coated high quality veneers		
	Width of backrest -425 mm		
	Height of backrest -380 mm		
	Writing pad material:- The folding writing pad of size 550x280mm is provided at the height 250mm from seat and fixing of the writing flap is done by using steel inserts and SS bolts only, fixed with 2mm thick J type plate which is carved inside the tablet to provide same level at the top of the tablet plate is welded on the round free pipe for giving easy and effortless folding operation. The seat, back and tablets are made with hot compressed water resistant ply and on the top glued with high quality veneers which are PU coated for scratch resistance and long life.		
	Writing pad size(Length x width in mm) :- J shape 550 x 280		
	Color of seat and backrest :- Bavarian Beech		
	Finishing of structure:- Powder coated		
	Plywood specification		
	Specific Gravity:1.10-1.25		
Percentage water absorption on immersion in water at 20 C for 24 hours : 5% - Minimum			
Cross breaking strength:			
Along the grain:1200 Kg/cm ² -Minimum			
Across the grain:600 Kg/cm ² -Minimum			

	<p>Surface impact strength:6 cm dia steel ball of 1 kg. Weight when dropped from a height of 1200 mm on a compressed ply board shall not result in any surface damage or cracking.</p>		
	<p>Impact strength perpendicular to the grain and top surface :</p>		
	<p>0.30 KG M- Minimum</p>		
	<p>Resistance to boiling water-When a sample of 19 mm thick compressed ply board (which is used for seat, flap & back of the chair) is subjected to boiling water test at 100° c for 8 hours, it shall not show any sign to disintegration or delaminating.</p>		
	<p>The weight of the single seater flap chair including all accessories shall not be less than 20 Kg. Variation on the minus side shall not be more than 1%.</p>		
	<p>Note:5 % of the total chair shall be with a writing pad on the left Hand users.</p>		

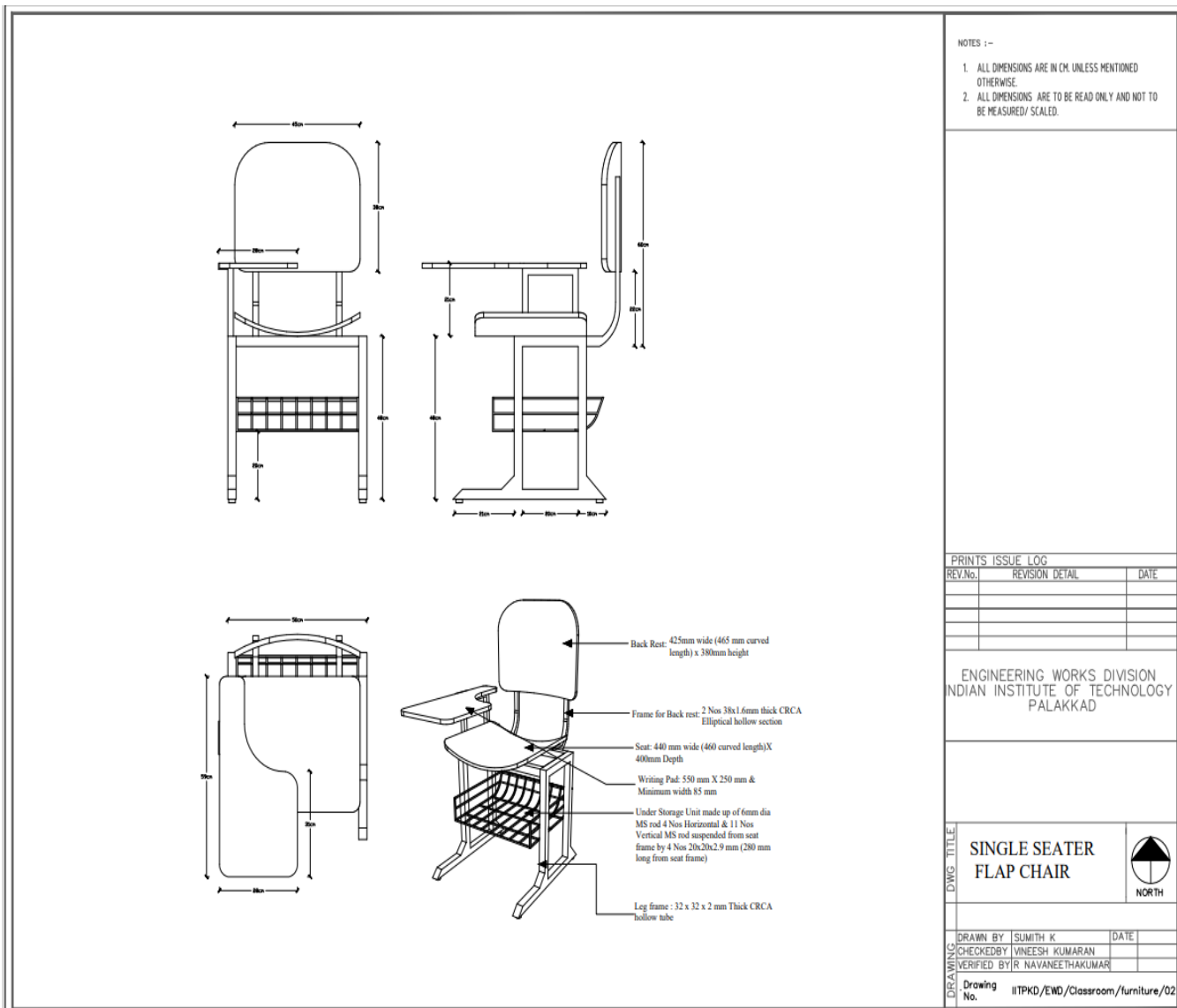

(Drawing also attached as separate attachment in the bid document)

FURNITURE UNLOADING LOCATION

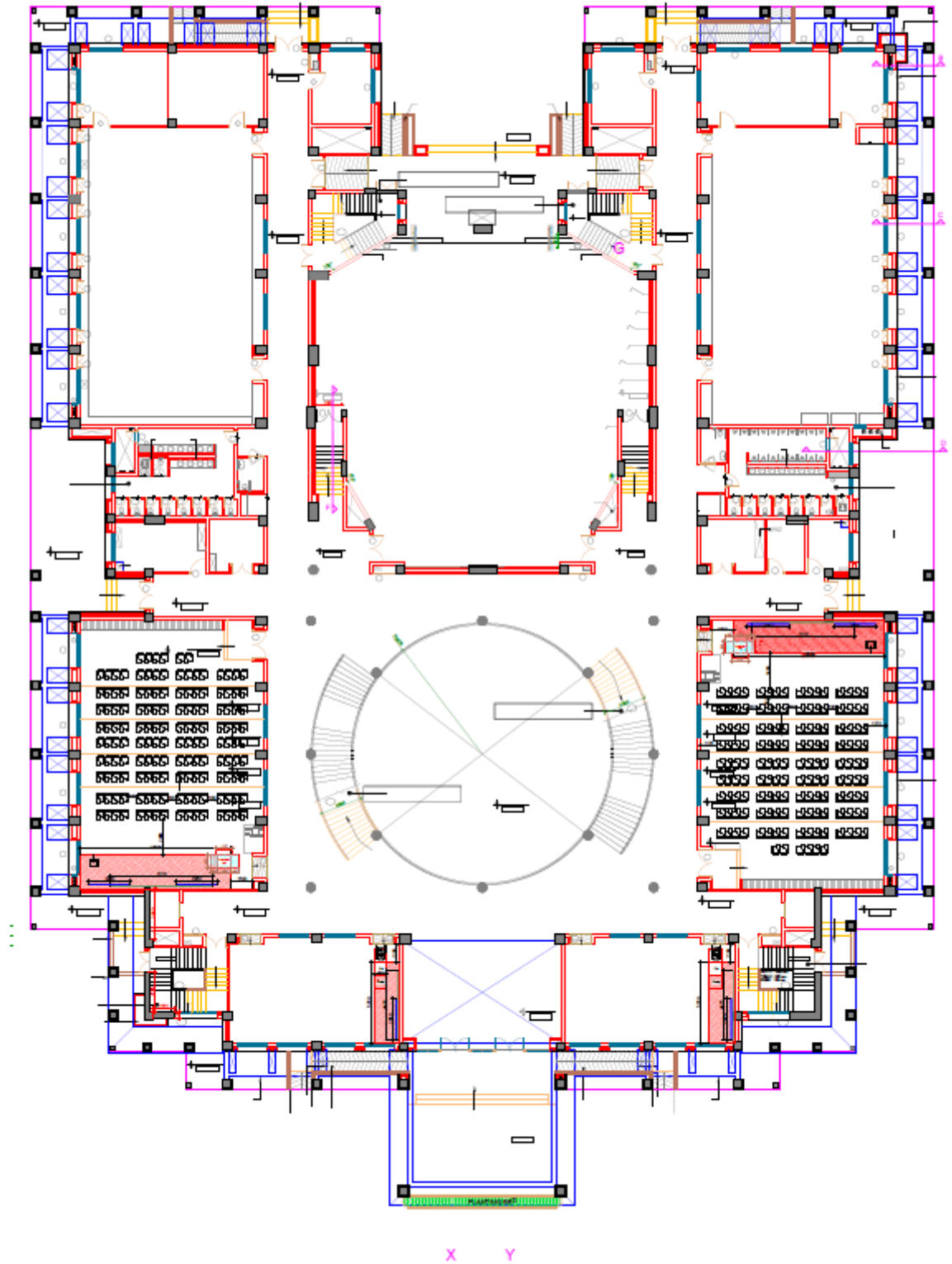

A01 GROUND FLOOR 300 FLAP CHAIR

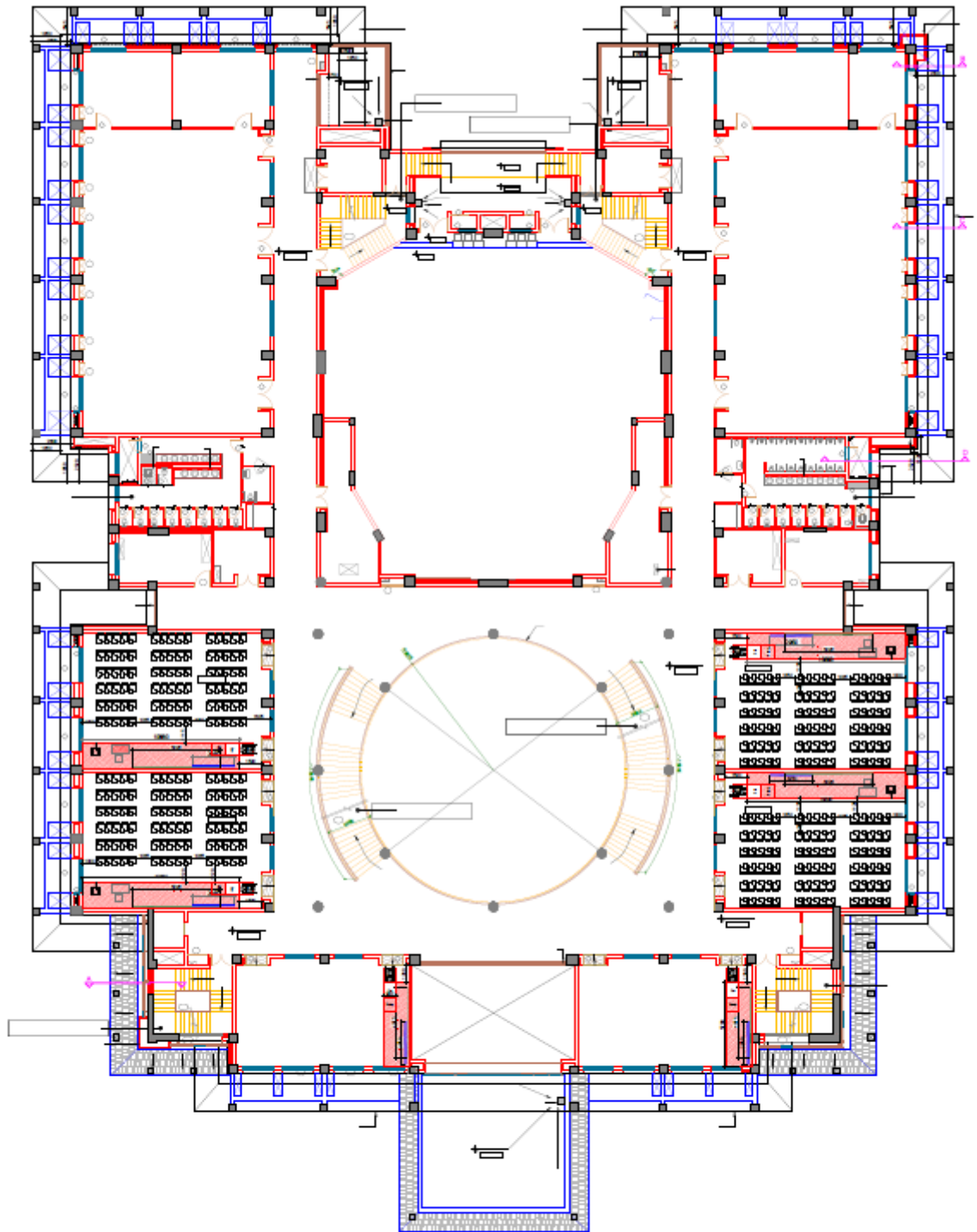

A01 FIRST FLOOR 360 FLAP CHAIR

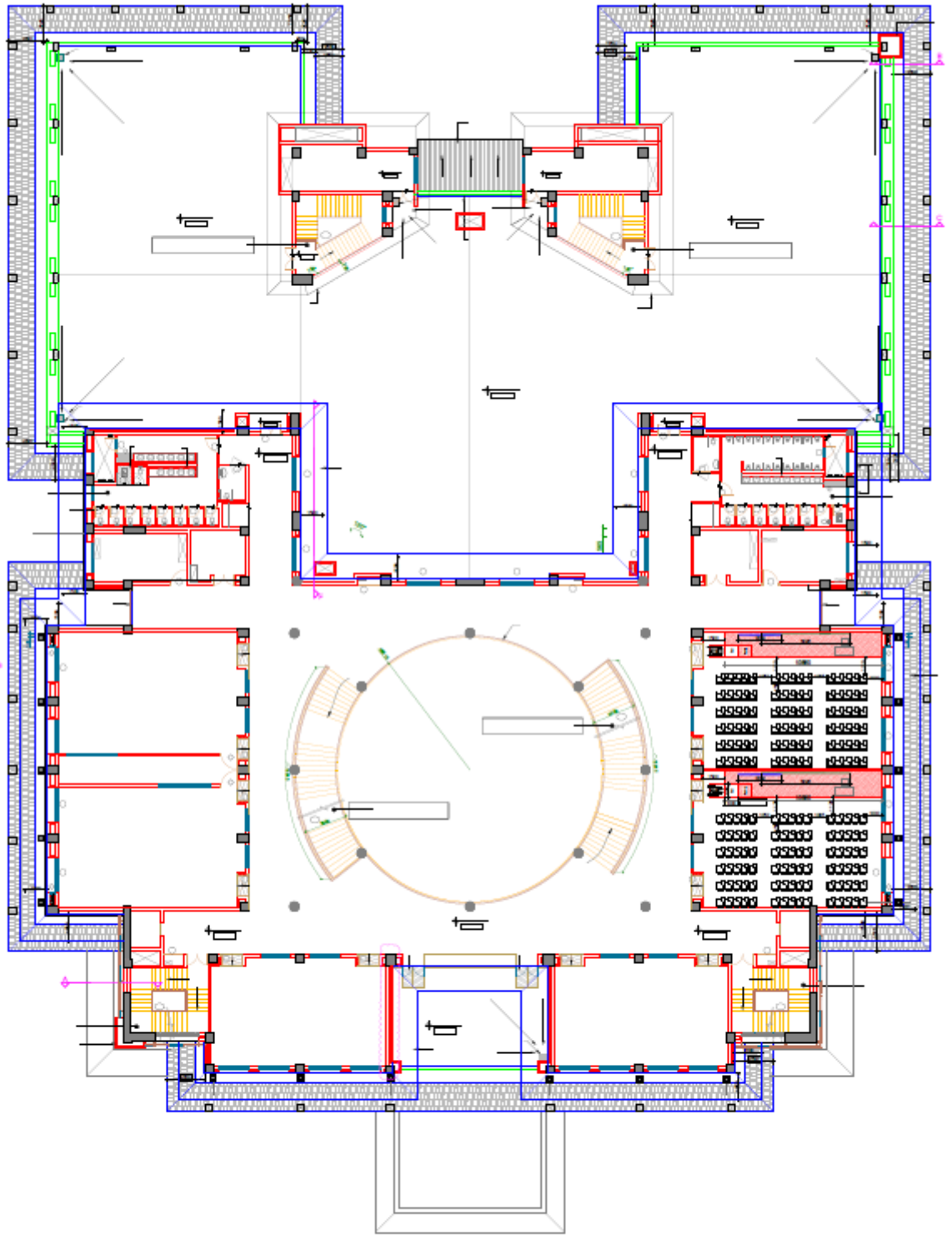

A01 SECOND FLOOR 180 FLAP CHAIR

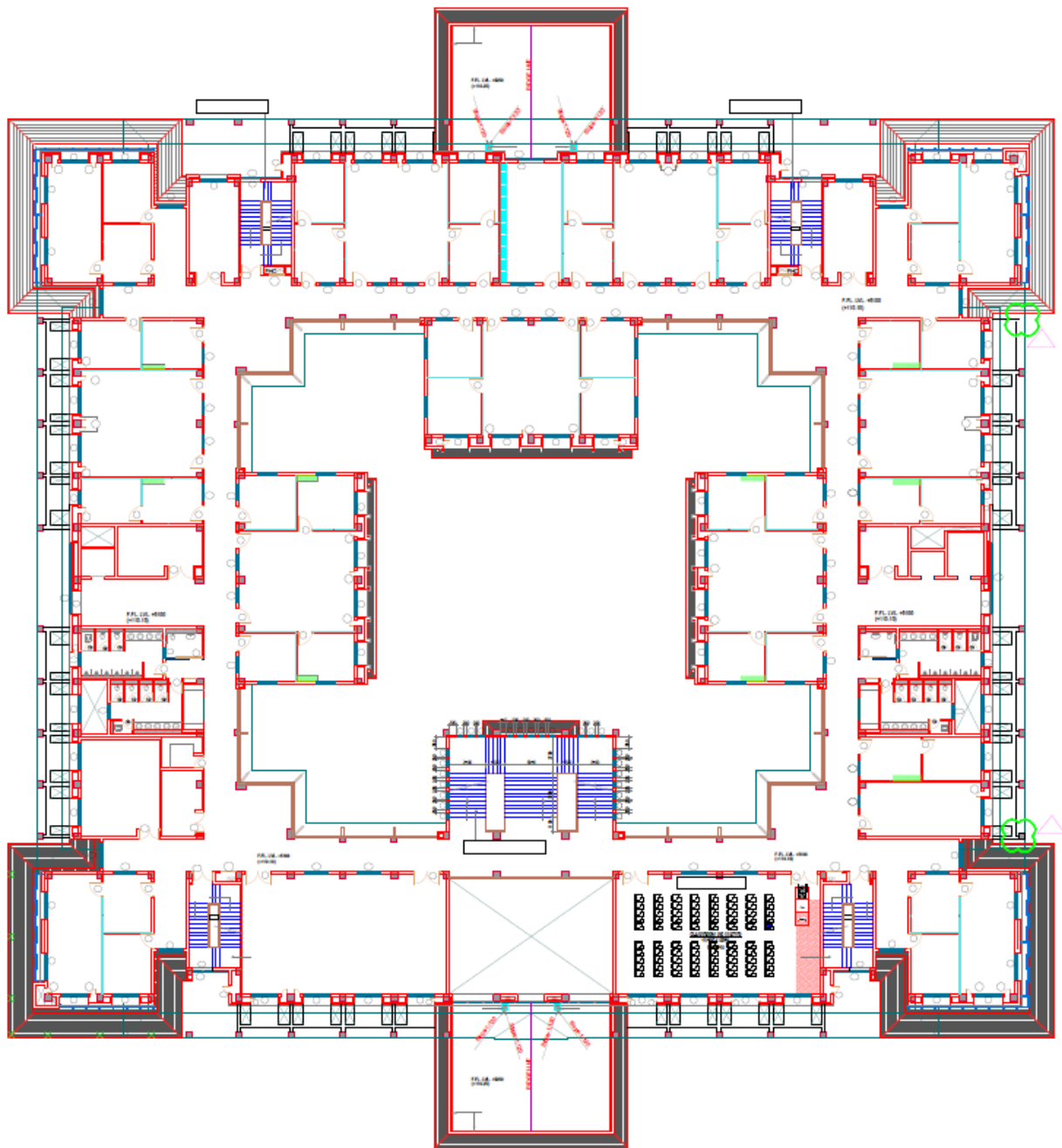

B04 FIRST FLOOR 80 FLAP CHAIR

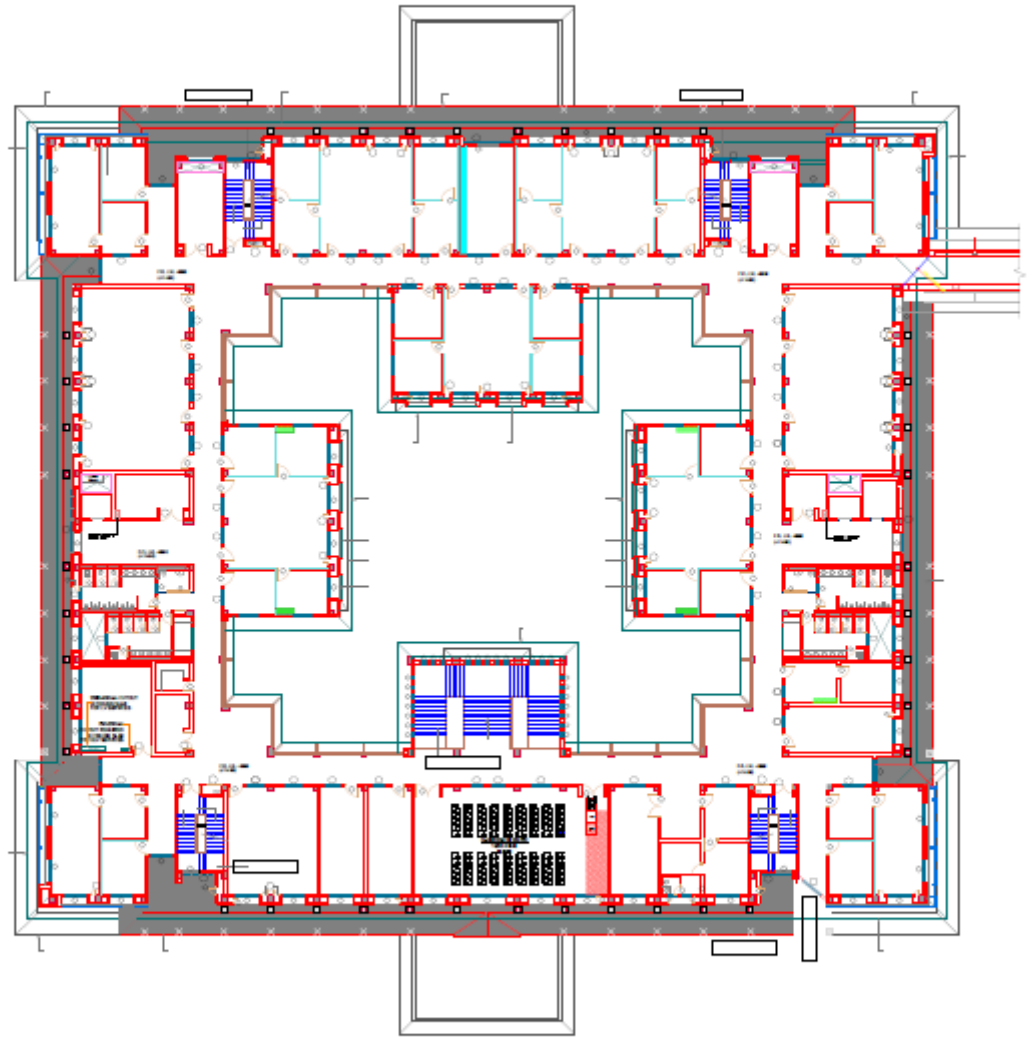

B04 SECOND FLOOR 55 FLAP CHAIR

(Drawing also attached as separate attachment in the bid document)

ANNEXURE – II
PRE-QUALIFICATION CRITERIA FOR BIDDERS

(To Be Submitted Only Through Online Mode in Appropriate Format)

Only those bidders fulfilling the following criteria should respond to the tender.

1. Bidder should be either an Original Furniture Manufacturer (OFM) or designer or authorized distributor of a furniture supplying to the Educational Institute.
2. The bidder should be a company registered under the Companies Act, 1956/2013 OR a Limited Liability Partnership / a registered partnership firm OR a sole- proprietorship entity. Appropriate Registration incorporation certificate must be submitted.
3. The bidder must also have a service center in Karnataka/Tamil Nadu/ Telangana/ Andhra Pradesh/ Maharashtra or Kerala. Certificate of registration for the centers to be provided.
4. Information related to the agency/bidder such as photocopies of the Registration/PAN/GST/TIN shall be furnished.
5. The technical bid should consist of all technical details along with terms and conditions. **No prices should be included in the technical bid. Mentioning of Prices in the Technical Bid shall lead to DISQUALIFICATION.**
6. Bidders who are bidding for this tender shall,
THREE similar completed works each costing not less than the amount equal to Rs. 54 Lakhs
(OR)
TWO similar completed works each costing not less than the amount equal to Rs. 67 lakhs
(OR)
ONE similar completed works each costing not less than the amount equal to Rs.108 lakhs
to Universities/Centrally Funded Technical Institutes /reputed organizations in India. Copies of certificate of successful implementation must be uploaded. Copies of financial statements or evidence of turnover must be uploaded. Similar work means “Furniture & Fittings, wooden Carpentry and fitting works, Steel furnitures and fittings works”
7. Have an Average Annual Turnover of **Rs.67 Lakh (RUPEES SIXTY SEVEN LAKH ONLY) during the last THREE financial years (2018-19, 2019-20,2020-21)**. The bidder shall enclose the audited statements of the indicated financial years, which should have been certified by a Chartered Accountant Or a Competent Authority.
8. Digitally signed Tender Document should be submitted in Cover One
9. The Institute reserves the right to ask for photographs/CAD drawings/ design proofs to satisfy themselves of the proven capabilities of the system being offered. The bidder must provide these details within two working days of receiving such a request via email. Decisions regarding technical compliance of the bidder can be taken on the basis of this information.

TECHNO-FINANCIAL BID**(To Be Submitted Only Through Online Mode in Appropriate Format)**

A. Company Profile
Name of the Company/Bidder
Postal Address of the Registered Office
Telephone (Landline) No.
Mobile No.
Email Address (Official)
Name of the CEO/Director
Name(s) of the Partners (if applicable)
Registration No. (Upload supporting document)
Type of Firm (Proprietary/Partnership/Private Ltd./Private/MNC/Cooperative/Govt. Undertaking/Any Other)
Email Address and Contact Number(s) of CEO/Director
Year of Establishment
No. of Years of Operations in India
Location of Offices in India / Abroad
PAN (Upload supporting document)
GST (Upload supporting document)
B. Alliances for the Purpose of this Bid, if applicable (Upload supporting document)
Details of Alliance(s)
Type of Alliance(s)
C. Experience/Credentials
No. of similar units installed in India
No. of similar units installed in Karnataka/Tamil Nadu/ Telangana/Andhra Pradesh or Kerala or any other nearby City/Town
List of Clients and Testimonials (Please upload necessary supporting document)
Year of Commencement of Manufacturing the Furniture (pertaining to this Bid)
D. Financial Background of the Firm - Annual Turnover (Upload supporting document signed by Competent Authority)
2018-19
2019-20
2020-21
E. Service Support and Availability of Spares in India
Track record of service provided during last 3 years (Upload supporting documents)
Location and Address of Service Centers
Number of trained Service Engineers
Number of trained Service Engineers exclusively dedicated to each Furniture offered
Number of trained service engineers for the Furniture offered, stationed in Karnataka/Tamil Nadu/ Telangana/Andhra Pradesh or Kerala
Number of Application Specialists
Whether the OEM offers any service
Whether the service set up maintains stock of Essential Spares in India
Lead time for Supply of Essential Spares
F. Others
Has the firm ever been debarred/blacklisted by any Govt. Organization/Dept.? If „yes“ the details thereof. Upload (supporting document)
Note: Supporting Documents, wherever asked for, shall be uploaded along with the Bid, without which the Bid shall be rejected outright.

**COMPLIANCE STATEMENT
(Part of Technical Bid)**

(To Be Submitted Only Through Online Mode in Appropriate Format)

The vendor shall,

1. Prepare, sign and upload the Compliance Statement of the specification of the Furniture in the format given below along with the technical bid in the company letter head.
2. Submit separate Compliance Statement of specification sheets for each item/ Furniture.
3. Ensure that the component number and heading in the Technical Specifications is clearly mentioned in the document. If there are any deviations from the specifications mentioned by IIT Palakkad, the vendor should clearly indicate the deviations and give reasons for the deviation with proper justification.
4. Provide the technical leaflet/literature/catalog or any relevant document for all the quoted Furniture to IIT Palakkad. The information provided in the compliance statement without supporting documents will not be considered for the evaluation of the technical bid and will be treated as non-compliance and may lead to the disqualification of the technical bid.
5. Clearly respond to every requirement given in the technical specifications. Lack of clarity may be considered as lack of information and may subsequently lead to disqualification of the technical bid.

Format of Compliance Statement:

Item No.	IIT Palakkad's technical specification of components as given in Annexure-I	Specifications of model quoted by the vendor	Vendor's specification complies with IIT Palakkad's technical specification? (YES/ NO)	Deviation, if any, to be indicated in unambiguous terms	Page no. of relevant specification for the quoted model in the technical manual/ leaflet

DECLARATION

We hereby undertake that there are _____ pages, serially numbered, in the submitted tender including the supporting documents. (Please serially number all the pages including blank pages, if any). We have submitted our principal's exclusive authorization letter which is specific for this tender No. _____ dated ____.

FALL CLAUSE UNDERTAKING
(To Be Submitted Only Through Online Mode in Appropriate Format)

This is to certify that we have offered the maximum possible discount to you in our Quotation No. _____ dated _____ **(Please do not reveal the prices here, which will lead to outright rejection of your bid)**. The prices charged for the Stores supplied under tender should under no event be higher than lowest prices at which the party sells the items of identical description to any other Govt. organization/PSU"s/Central Govt, /State Govt. Autonomous bodies/Central/state Universities/Central/State Educational Institutions, failing which the "**FALL CLAUSE**" will be applicable. The institute will look into a reasonable past period to ensure this. In case, if the price charged by our firm is found to be more, **IIT Palakkad** will have the right to recover the excess charged amount from the subsequent/unpaid bill of the supplier.

Note:

This letter of authority should be on the letterhead of the quoting firm and should be signed by a Competent Authority and having the power of attorney.

FORMAT FOR SELF-CERTIFICATION UNDER PREFERENCE TO MAKE IN INDIA
(TO BE SUBMITTED ONLY THROUGH ONLINE MODE IN APPROPRIATE FORMAT)

Format for Affidavit of Self-Certification regarding Minimum Local Content in line with "Make in India" Policy vide GoI Order no. P-45021/2/2017-PP (B.E.-II) dated 15.06.2017 (subsequently revised vide orders dated 28.05.2018, 29.05.2019 and 04.06.2020)

Date: _____
 I/We _____ S/o, D/o, W/o, _____
 Resident of _____

Hereby solemnly affirm and declare as under:

That I will agree to abide by the terms and conditions of the Public Procurement (Preference to Make in India) Order, 2017 (hereinafter PPP-MII order) of Government of India issued vide Notification No:P-45021/2/2017 -BE-II dated 15/06/2017, its revision dated 28/05/2018 and any subsequent modifications/Amendments, if any and

That the local content for all inputs which constitute the said goods/services/works has been verified by me and I am responsible for the correctness of the claims made therein.

Tick (✓) and Fill the Appropriate Category	
<input type="checkbox"/>	I/We _____ [name of the manufacturer] hereby confirm in respect of quoted items(s) that Local Content is equal to or more than 50% and come under " Class-I Local Supplier " category.
<input type="checkbox"/>	I/We _____ [name of the manufacturer] hereby confirm in respect of quoted items(s) that Local Content is more than 20% but less than 50% and come under " Class-II Local Supplier " category.
<input type="checkbox"/>	I/We _____ [name of the manufacturer] hereby confirm in respect of quoted items(s) that Local Content is less than or equal to 20% come under " Non-Local Supplier " category.

For and on behalf of..... (Name of firm/entity)

Authorized signatory (To be duly authorized by the Board of Directors)
 <Insert Name, Designation and Contact No.>

[Note: In case of procurement for a value in excess of Rs. 10 Crores, the bidders shall provide this certificate from statutory auditor or cost auditor of the company (in the case of companies) or from a practicing cost accountant or practicing chartered accountant (in respect of suppliers other than companies) giving the percentage of local content.]

ACKNOWLEDGMENT FOR RECEIPT OF SAMPLE FURNITURE

TENDER NO. 17/IITPKD/EWD/2022-23/009

**NAME OF WORK: CONSTRUCTION OF PERMANENT CAMPUS FOR IIT PALAKKAD
UNDER PHASE 1A SH: FURNITURE SW: SUPPLY AND INSTALLATION OF SINGLE
SEATER FLAP TYPE CHAIR FOR CLASSROOMS IN A01, B03, B04 AT MAIN CAMPUS**

NAME AND ADDRESS OF THE BIDDER :

SAMPLE SUBMISSION DATE / TIME:

SAMPLE RECEIVED DATE /TIME BY EWD:

SAMPLE RECEIVED BY :

SIGNATURE OF EXECUTIVE ENGINEER, EWD, IITPKD