



IIT PALAKKAD

Indian Institute of Technology Palakkad

भारतीय प्रौद्योगिकी संस्थान पालक्काड

Nurturing Minds For a Better World

NOTICE INVITING TENDER FOR

**Name of work: Construction of Permanent Campus under Phase 1 A,
SH: Furniture & Fittings
SW: Furnishing of Materials Lab at Ground Floor, Classroom cum Laboratory
Complex (C06), Sahyadri Campus**

TENDER NO. 17/IITPKD/EWD/CIVIL/2024-25/034

S. No.	Events	Date and Time
1	Notice Inviting BID (NIT) No.	17/ IITPKD/EWD/2024-25/034
2	Date of Publication	08-11-2024
3	Date / Time of closing	22-11-2024, 1500 hrs
4	Opening of Eligibility cum technical Bids	22-11-2024,1530 hrs
5	Estimated Cost put to bid	Rs. 4,19,136/-
6	Earnest Money Deposit (EMD)	Rs.8383/-

Engineering works Division
Indian Institute of Technology Palakkad
Kanjikode West, Palakkad – 678 623
Email: ewd@iitpkd.ac.in

Indian Institute of Technology Palakkad (hereinafter called "IITPKD") invites **ONLINE** item rate Bids (Cover-1: Eligibility cum technical Bid, Cover-2: Financial Bid) from approved and eligible contractors at Sahyadri Campus, Pudukkottai PO, Kanjikode West, Palakkad- 678623. Interested bidders may submit their bids ONLINE at <https://mhrd.euniwizarde.in/>

1.	Name of Work	Name of work: Construction of Permanent Campus under Phase 1 A, SH: Furniture & Fittings SW: Furnishing of Materials Lab at Ground Floor, Classroom cum Laboratory Complex (C06), Sahyadri Campus
2.	Estimate Cost put to Tender	Rs.4,19,136
3.	Earnest Money Deposit (EMD)	Rs.8383/- Bids without paying the EMD in gateway of E- Wizard portal shall be DISQUALIFIED
4.	Period of completion	60 Days
5.	Validity of the tender	75 days from the date of opening of eligibility bid.
6.	Last Date for Submission of e-Tender	22-11-2024, 1500 hrs
7.	Date of Opening of the Eligibility document	22-11-2024,1530 hrs
8.	Date of opening of the financial bid	Will be intimated later to eligible bidders through online in E- Wizard portal

DEFINITION

Officer inviting tender : Chairman, EWD

Engineer in charge : Executive Engineer (Civil), EWD

Accepting authority : Chairman, EWD

Time allowed for submission of Performance security : 7 days

Maximum allowable extension with late fee at the rate of 0.1% of PS per day beyond the period of 7 days - 5 days.

No of days from the date of issue of letter of acceptance for recurring date of start : 7 days

1.GENERAL

- 1.1 Indian Institute of Technology Palakkad (hereinafter called "IITPKD") invites online item rate tenders under two-bid System. The bid document consists of a schedule of quantities of various items to be executed, scope of works, terms and conditions of the contract and other necessary documents can be seen and downloaded from <https://mhrd.euniwizarde.in/>.
- 1.2 The bids will be opened by the competent authority of IIT Palakkad on behalf of the IIT Palakkad
- 1.3 The bids shall be submitted online in E- Wizard Portal (<http://mhrd.euniwizarde.in/>)
- 1.4 The responsibility of submission of the bids on or before the last date shall rest with the tenderer.
- 1.5 Canvassing, whether directly or indirectly, in connection with bids is strictly prohibited and the bids submitted by the contractors who resort to canvassing will be liable for rejection.
- 1.6 The bidder shall bear all costs associated with the preparation and submission of his bid and IITPKD shall in no case be responsible or liable for those costs, regardless of the conduct or outcome of the tender process.
- 1.7 IITPKD will respond to any request for clarification or modification of the Tender Document that is received up to FIVE (05) days prior to the deadline for submission of bids prescribed by IITPKD. For this purpose, the prospective bidder(s) requiring clarification in the Tender Document shall notify IITPKD in writing at the address mentioned. Any such clarification, together with all details on which the clarification had been sought, will be published on the E-Wizard website. Post tender clarification will not be accepted.
- 1.8 Except for any such clarification by the Institute, which is expressly stated to be an addendum/Corrigendum to the tender document issued by the Chairman, EWD, IIT Palakkad, no written or oral communication, presentation, or explanation by any other employee of any of the Sections/Departments of the Institute, shall be taken to bind or fetter the Institute.

1.9 EARNEST MONEY DEPOSIT (EMD)

- i. The bidder shall furnish EMD of **Rs.8383/-** through an online payment gateway in the E-Wizard.
- ii. Bids without paying the EMD in gateway of E- Wizard portal shall be DISQUALIFIED.
- iii. EMD of the successful bidder shall be returned on receipt of the prescribed Performance Security and after signing of the contract agreement.
- iv. EMD of the unsuccessful bidders will be returned to them at the earliest after expiry of the final bid validity and latest by the 30th day after the award of the contract.
- v. 100% EMD shall be forfeited
 - a. if the bidder withdraws his bid during the period of validity of the tender.
 - b. if the successful bidder refuses or neglects to execute the contract or fails to furnish the required Performance Security within the time frame specified by the Institute.
 - c. if the successful bidder fails to execute the Contract on specified timeline

1.10 EXEMPTION OF EMD

- 1) The firms who are registered with National Small Industries Corporation (NSIC) / or Small Scale Industrial (SSI)/ Micro & Small Enterprises (MSEs) are exempted from furnishing the EMD. Self-attested photocopy of valid registration certificate issued by competent authority for "**Furniture & Fittings'** to be uploaded with the eligibility bid for exemption of EMD. The benefit as above to MSMEs shall be available only

as Goods produced and service rendered by MSMEs. However, traders are excluded from the purview of MSE Procurement Policy.

- 2) Startup (s):
Startup(s) as recognized by the Department as Promotion of Industry and Internal Trade (DPIIT), Govt. of India, are exempted from EMD. However, they have to enclose valid self-attested registration certificate(s) along with the tender to this effect..
- 3) Eligible MSE and startup bidders who seeks exemption from EMD as per clause no. (c) above, if they withdraw or modify their bids during the period of validity, or if they are awarded the contract and they fail to sign the contract, or to submit a Performance security within the timeline defined in the bid document, they will be suspended as the period of three years or as decided by the competent authority from being eligible to submit bids as contracts with the entity that invited the bids.
- 4) Other than eligible MSE and Startup bidders, EMD: The Bidders should pay the EMD through the E- wizard Portal.

2. ADDENDUM / CORRIGENDUM IN THE TENDER DOCUMENT

- 2.1. At any time prior to the deadline for submission of bids, IITPKD may, for any reason, whether at its own initiative or in response to a clarification requested by a prospective Bidder, modify the Tender Document by way of amendment(s)/ Corrigendum
- 2.2. Addendum/Corrigendum will be intimated through the E- Wizard portal and the bidders shall ensure that the addendums are carried out in the bid before submission. The addendums will not be published in newspapers. Bidders should regularly visit the E-Wizard portal to keep themselves updated.
- 2.3. No extension in the bid due date/ time shall be considered on account of delay in submission of bid.

3. COMPOSITION OF THE TENDER DOCUMENT

- 3.1 The Tender Document comprises of:
 - (a) Schedule of Quantity (Annexure - I)
 - (b) Pre-qualification Criteria (Annexure-II)
 - (c) Documents to be uploaded (Annexure III)
 - (d) Format of Performance Security (Annexure-IV)
 - (e) Declaration (Annexure-V)
 - (f) Fall clause notification certificate (Annexure VI)
 - (g) Declaration for not blacklisted / debarred (Annexure X)
 - (h) Letter of Transmittal (Annexure - VII)
 - (i) Details of similar work (Form A)
 - (j) Performance report for the completed works (Form B)

The bidder shall not make or cause to be made any alteration, erasure or obliteration to the text of the Tender Document.

4. LANGUAGE/FORMAT/SIGNING OF THE BID

- 4.1. The bid prepared by the Bidder and all correspondence and documents related to the tender exchanged by the Bidder and IITPKD shall be in English and the Contract shall be construed and interpreted in accordance with that language. If any of the brochures, leaflets or communication is prepared in any language other than English, a translation of such document, correspondence or communication shall also be provided at the cost and risk of the bidder. The translation so provided shall prevail in matters of interpretation. The bidder, with respect to such documents, correspondence and communications, shall bear the costs and risks of such translation.
- 4.2. The bid shall not contain any internalizations, erasures, overwriting, except to correct errors made by the bidder, in which case the person or persons signing the bid shall initial such corrections with date.

5. Bids submitted in any mode other than ONLINE will be rejected outright. No prices should be included in the technical bid. Financial Bid should be filled as per the format given in the financial bid document. Indicating Price in the eligibility bid will be disqualify.

5.1 All offered products' technical Specifications and Brochures are to be submitted along with the Technical Bid

6. ITEM RATE CONTRACT

The bidder should quote the Item rate for each item. If any cells (Rates) left Blank in the Financial bid (Cover 2), then the same will be treated "ZERO". The contractor must ensure to quote the rate in prescribed columns. The column meant for quoting rate in figures appears in Yellow color and the moment rate is entered, it turns sky blue. In addition to this, while selecting any of the cells a warning appears that if any cell is left blank the same shall be treated as ZERO. Therefore, if any cell is left blank and no rate is quoted by the bidder, the rate of such an item shall be treated as "0" (ZERO). However, if a tenderer quotes nil rates against each item in item rate tender or does not quote any percentage above/below on the total amount of the tender or any section / subhead in percentage rate tender, the tender shall be treated as invalid and will not be considered as lowest tenderer.

7. CONFORMITY OF THE TENDER DOCUMENT

The bid document consisting of specifications, the schedule of quantities of various items to be executed and the terms and conditions of the contract and other necessary documents can be seen in the tender document.

8. PERIOD OF VALIDITY OF BIDS

Bids shall remain valid for a period of **60 days** after the date of deadline for submission of bids prescribed by the Institute.

9. MODIFICATION AND WITHDRAWAL OF BIDS

The bidders may modify or withdraw the bid after submission only through ONLINE mode, within the period of deadline for submission of bids. No bids can be modified subsequent to the deadline for submission of Bids. No bids can be withdrawn in the interval between the bid submission deadline and the expiration of the bid validity period.

10. OPENING AND EXAMINATION OF BIDS

10.1. The Technical bids will be opened on the prescribed date and time as mentioned in the Bid document in ONLINE mode.

10.2. The Institute will evaluate the technical bids for the eligibility criteria. Those bids who satisfy the eligibility criteria will be considered for opening their financial bids. Those bids which are found to be either non-responsive, or not satisfying the eligibility criteria will not be considered for opening their financial bids and will be rejected.

10.3. The date of opening of financial bid (cover 2) will be intimated later to the eligible bidders through E- wizard portal.

10.4. Arithmetical errors will be rectified on the following basis. If there is a discrepancy between the unit price and the total price, which is obtained by multiplying the unit price and quantity, or between subtotals and the total price, the unit or subtotal price shall prevail and the total price shall be corrected. If there is a discrepancy between words and figures, the amount in words shall prevail.

11. CLARIFICATION OF BIDS

During the bid evaluation, the Institute may, at its discretion, ask the Bidder for a clarification of its bid. The request for clarification and the response shall be through ONLINE mode ONLY and no change in the price or substance of the bid shall be sought, offered or permitted.

12. AWARD CRITERIA

The competent authority on behalf of the IIT Palakkad does not bind itself to accept the lowest or any other bid and reserves to itself the authority to reject any or all the bids received without assigning any reason. All bids in which any of the prescribed conditions is not full fill including that of conditional rebate is put forth by the bidders shall be summarily rejected. The competent authority on behalf of the IIT Palakkad reserves to himself the right to accept the whole or any part of the bid and the bidders shall be bound to perform at the rates quoted.

The Institute reserves the right to buy different items/quantities from different bidders considering price of individual/group of furniture or any other factors as decided by the Institute.

13. INSTITUTE RIGHT TO ACCEPT/REJECT BIDS

The Institute reserves the right to accept or reject any bid or to annule the bidding process and reject all bids at any time prior to Contract award, without thereby incurring any liability to the Bidders.

14. AWARD OF WORK/PURCHASE ORDER

Prior to the expiration of the period of bid validity, the institute will issue the Work Order to the successful Bidder in writing. The Work Order will form part of the Contract.

15. CONTRACT AGREEMENT

On receipt of work Order from the Chairman (EWD), the successful bidder shall sign with the date on each page of the work order and return it to the Chairman EWD, along with the Performance Security. Copy of the Work Order duly signed by the successful Bidder on each page shall constitute the Contract Agreement.

16. PERFORMANCE SECURITY

Within SEVEN DAYS of receipt of notification of award from the Chairman EWD, the successful Bidder shall furnish the performance security equal to 5% of the Contract value The Performance Security shall be valid all along the contract period and shall extend up to sixty (60) days after the date of completion of work accepted by the Engineer in Charge.

The performance security shall be a bank guarantee (in the format as provided in (in the format as provided in Annexure- IV of the bidding documents) issued by any Scheduled Bank in India acceptable to the Purchaser or a Demand Draft favoring, INDIAN INSTITUTE OF TECHNOLOGY PALAKKAD payable at PALAKKAD. The performance security shall be returned to the contractor not later than fifteen (15) days after its expiration.

16.1 SECURITY DEPOSIT : 2.5% of tendered value. The contractor whose tender is accepted will also be required to furnish by way of Security Deposit for the fulfillment of his contract, an amount equal to 2.5% of the tendered value of the work. Fixed Deposit Receipt of a Scheduled Bank or will also be accepted for this purpose provided confirmatory advice is enclosed.

16.2 Release of Security Deposit : After the defect the liability period as per clause no.

16.3 CONTRACTOR LIABLE FOR DAMAGES, DEFECTS DURING DEFECT LIABILITY PERIOD (12 MONTHS)

If the contractor or his working people or servants shall break, deface, injure or destroy any part of building in which they may be working, or any building, road, road kerb, fence, enclosure, water pipe, cables, drains, electric or telephone post or wires, trees, grass or grassland, or cultivated ground contiguous to the premises on which the work or any part is being executed, or if any damage shall happen to the work while in progress, from any cause whatever or if any defect, shrinkage or other faults appear in the work within twelve months (six months in the case of work costing Rs. Ten lakhs and below except road work) after a certificate final or otherwise of its completion shall have been given by the Engineer in- Charge as aforesaid arising out of defect or

improper materials or workmanship the contractor shall upon receipt of a notice in writing on that behalf make the same good at his own expense or in default the Engineer-in-Charge cause the same to be made good by other workmen and deduct the expense from any sums that may be due or at any time thereafter may become due to the contractor, or from his security deposit or the proceeds of sale thereof or of a sufficient portion thereof. The security deposit of the contractor shall not be refunded before the expiry of twelve months (six months in the case of work costing Rs. Ten lakhs and below except road work) after the issue of the certificate final or otherwise, of completion of work, or till the final bill has been prepared and passed whichever is later. Provided that in the case of road work, if in the opinion of the Engineer-in-Charge, half of the security deposit is sufficient, to meet all liabilities of the contractor under this contract, half of the security deposit will be refundable after six months and the remaining half after twelve months of the issue of the said certificate of completion or till the final bill has been prepared and passed whichever is later

17. CONTRACT DOCUMENTS

All documents forming part of the Contract (and all parts of these documents) are intended to be correlative, complementary and mutually explanatory. The Contract shall be read as a whole. The order of precedence of the Contract documents shall be as follows:

1. Contract Agreement
2. All other Forms
3. Bid documents

18. AMENDMENT TO CONTRACT

No amendment or other variation of the Contract shall be effective unless it is in writing, is dated, expressly refers to the Contract and is signed by a duly authorized representative of each party to the Contract.

19. CONTRACTORS RESPONSIBILITIES

The Contractor's obligations involve:

The work shall be executed as per Schedule of quantity / CPWD specifications and as per direction of Engineer /officer in charge of IIT Palakkad.

The contractors are advised to make site visits before participating in the tender. No such escalation claims will be entertained once taken up the work for any items mentioned in the schedule of quantity.

The supplying materials related to work completion, necessary transportation permits should be taken care of by the contractor. The work to be completed by the contractor at site including loading unloading transportation, handling & rehandling and required manpower charges etc.

20. TIME ALLOWED FOR CARRYING OUT THE WORK

The time allowed for carrying out the work will be **45 days** from the date of start. The date of start shall commence from the 7th day of issue of work order. The agency shall complete the work within the period specified in the tender document and sign the work order or within the period mutually agreed between Institute and Contractor.

21. TERMS OF PAYMENT

No Advance payment will be made. Running account shall be made by the Executive Engineer, EWD as per the Execution of items in the BOQ. Gross work to be done together with net payment /adjustment of advances for material collected, if any, since the last such payment for being eligible to interim payment - **Rs. 2 Lakhs**

The final bill shall be submitted by the contractor in the same manner as specified in interim bills within three months of physical completion of the work or within one month of the date of the final certificate of completion furnished by the Engineer-in-Charge whichever is earlier.

No further claims shall be made by the contractor after submission of the final bill and these shall be deemed to have been waived and extinguished. Payments of those

items of the bill in respect of which there is no dispute and of items in dispute, for quantities and rates as approved by Engineer-in-Charge, will, as far as possible be made within the period specified here in under, the period being reckoned from the date of receipt of the bill by the Engineer-in-Charge, complete with account of materials issued by the Department and dismantled materials.

(a) If the Tendered value of work is up to 1 Crore : 2 months

(b) If the Tendered value of work is more than Rs 1 Crore and up to Rs. 10 Crore : 3 months

22. TAXES AND DUTIES

The Contractor should ensure payment of all taxes, GST, levies and charges assessed by all municipal, state or national government authorities, in connection with the Goods and Services supplied under the Contract. Nothing extra shall be paid on any account. Rates quoted shall be inclusive of all taxes and duties

23. ASSIGNMENT

The agency shall not assign to any third party of the awarded Contract or any part thereof without the prior written consent of the Institute

24. GOVERNING LAW

The Contract shall be governed by and interpreted in accordance with the laws of India.

25. TIME AND EXTENSION FOR DELAY

The time allowed for execution of the Works shall be **45 days** or the extended time in accordance with these conditions given below shall be the essence of the Contract. The execution of the work shall commence from such time period as mentioned in the Bid or from the date of handing over of the site, notified by the Engineer-in-Charge, whichever is later. If the Contractor commits default in commencing the execution of the work as aforesaid, the performance guarantee shall be forfeited by the Engineer in Charge and shall be absolutely at the disposal of the Institute without prejudice to any other right or remedy available in law.

25.1 As soon as possible but within 7 (seven) working days of award of work and in consideration of

(a) Schedule of handing over of site as specified in the bid

(b) Schedule of issue of drawings if applicable as specified in the bid

- i. The Contractor shall submit a Time and Progress Chart for each milestone. The Engineer-in-Charge may within 7 (seven) working days thereafter, if required modify, and communicate the program approved to the contractor failing which the program submitted by the contractor shall be deemed to be approved by the Engineer-in-Charge. The work programme shall include all details of balance drawings and decisions required to complete the contract with specific dates by which these details are required by the contractor without causing any delay in execution of the work. The Chart shall be prepared in direct relation to the time stated in the Contract documents for completion of items of the works. It shall indicate the forecast of the dates of commencement and completion of various trades of sections of the work and may be amended as necessary by agreement between the Engineer-in-Charge and the Contractor within the limitations of time imposed in the Contract documents.
- ii. In case of non submission of a construction programme by the contractor the program approved by the Engineer-in-Charge shall be deemed to be final.
- iii. The approval by the Engineer-in-Charge of such a programme shall not relieve the contractor of any of the obligations under the contract.
- iv. The contractor shall submit the Time and Progress Chart and progress report using the mutually agreed software or in other format decided by Engineer-in-Charge for the work done during previous month to the Engineer-in-charge on or before 5th day of each month failing which a recovery of Rs.1000 / week

shall be made per week or part basis in case of delay in submission of the monthly progress report .

25.2 If the work(s) be delayed by:-

- (i) force majeure, or
- (ii) abnormally bad weather, or
- (iii) serious loss or damage by fire, or
- (iv) civil commotion, local commotion of workmen, strike or lockout, affecting any of the trades employed on the work, or
- (v) delay on the part of other contractors or tradesmen engaged by Engineer-in-Charge in executing work not forming part of the Contract, or
- (vi) any other cause like above which, in the reasoned opinion of the Engineer-in-Charge is beyond the Contractor's control.

then upon the happening of any such event causing delay, the Contractor shall immediately give notice thereof in writing to the Engineer-in-Charge but shall nevertheless use constantly his best endeavors to prevent or make good the delay and shall do all that may be reasonably required to the satisfaction of the Engineer-in-Charge to proceed with the works. The contractor shall have no claim of damages for extension of time granted or rescheduling of milestone/s for events listed in sub clause 25.2.

The contractor shall have no claim of damages for extension of time granted or rescheduling of milestone/s for events listed in sub clause above

25.3 In case the work is hindered by the Department or for any reason/event, for which the Department is responsible. The authority as indicated in Bid , if justified, give a fair and reasonable extension of time and reschedule the milestones for completion of work Such extension of time or rescheduling of milestone/s shall be without prejudice to any other right or remedy of the parties in contract or in law; provided further that for concurrent delays under this sub clause and sub clause 25.2 to the extent the delay is covered under sub clause above the contractor shall be entitled to only extension of time and no damages. Request for rescheduling of Milestones or extension of time and no damages.

25.4 Request for rescheduling of Milestones or extension of time, to be eligible for consideration, shall be made by the Contractor in writing within fourteen days of the happening of the event causing delay on the prescribed forms i.e. Form of application by the contractor for seeking rescheduling of milestones or Form of application by the contractor for seeking extension of time respectively to the authority as indicated in Bid. The Contractor shall indicate in such a request the period by which rescheduling of milestone/s or extension of time is desired. With every request for rescheduling of milestones, or if at any time the actual progress of work falls behind the approved programme by more than 10% of the stipulated period of completion of contract, the contractor shall produce a revised programme which shall include all details of pending drawings and decisions required to complete the contract and also the target dates by which these details should be available without causing any delay in execution of the work. A recovery as specified in Bid shall be made on a per day basis in case of delay in submission of the revised programme.

25.4.1 In any such case the authority as indicated in Bid may give a fair and reasonable extension of time for completion of work or reschedule the milestones. Engineer -in-Charge shall finalize/ reschedule a particular mile stone before taking an action against subsequent mile stone .Such extension or rescheduling of the milestones shall be communicated to the Contractor by the authority as indicated in Bid in writing, within 21 days of the date of receipt of such request from the Contractor in prescribed form. In event of non application by the contractor for extension of time E-in-C after affording opportunity to the contractor, may give, supported with a

programme a fair and reasonable extension within a reasonable period of occurrence of the event.

25.5 In case the work is delayed by any reasons, in the opinion of the Engineer-in-Charge, by the contractor for reasons beyond the events mentioned in clause 25.2 or clause 25.3 or clause 25.4 and beyond the justified extended date; without prejudice to right to take action under Clause 26, the Engineer-in-Charge may grant extension of time required for completion of work without rescheduling of milestones. The contractor shall be liable for levy of compensation for delay for such extension of time

26. WHEN CONTRACT CAN BE DETERMINED

Subject to other provisions contained in this clause, the Engineer-in-Charge may, without prejudice to any other rights or remedy against the contractor in respect of any delay, not following safety norms, inferior workmanship, any claims for damages and/or any other provisions of this contract or otherwise, and whether the date of completion has or has not elapsed, by notice in writing absolutely determine the contract in any of the following cases:

i) If the contractor having been given by the Engineer-in-Charge a notice in writing to rectify, reconstruct or replace any defective work or that the work is being performed in an inefficient or otherwise improper or un-workman like manner shall omit to comply with the requirement of such notice for a period of seven days thereafter.

(ii) If the contractor has, without reasonable cause, suspended the progress of the work or has failed to proceed with the work with due diligence and continues to do so after a notice in writing of seven days from the Engineer-in-Charge.

(iii) If the contractor fails to complete the work or section of work with individual date of completion on or before the stipulated or justified extended date, on or before such date of completion; and the Engineer in Charge without any prejudice to any other right or remedy under any other provision in the contract has given further reasonable time in a notice given in writing in that behalf as either mutually agreed or in absence of such mutual agreement by his own assessment making such time essence of contract and in the opinion of Engineer-in-Charge the contractor will be unable to complete the same or does not complete the same within the period specified.

(iv) If the contractor persistently neglects to carry out his obligations under the contract and/ or commits default in complying with any of the terms and conditions of the contract and does not remedy it or take effective steps to remedy it within 7 days after a notice in writing is given to him in that behalf by the Engineer-in-Charge.

(v) If the contractor shall offer or give or agree to give to any person in Government service or to any other person on his behalf any gift or consideration of any kind as an inducement or reward for doing or forbearing to do or for having done or forborne to do any act in relation to the obtaining or execution of this or any other contract for Government.

(vi) If the contractor shall enter into a contract with Government in connection with which commission has been paid or agreed to be paid by him or to his knowledge, unless the particulars of any such commission and the terms of payment thereof have been previously disclosed in writing to the Engineer-in-Charge.

(vii) If the contractor had secured the contract with the Government as a result of wrong tendering or other non-bonafide methods of competitive tendering or committed a breach of Integrity Agreement.

(viii) If the contractor being an individual, or if a firm, any partner thereof shall at any time be adjudged insolvent or have a receiving order or order for administration of his estate made against him or shall take any proceedings for liquidation or composition (other than a voluntary liquidation for the purpose of amalgamation or reconstruction) under any Insolvency Act for the time being in force or make any conveyance or assignment of his effects or composition or arrangement for the benefit of his creditors or purport so to do, or if any application be made under any Insolvency Act for the time

being in force for the sequestration of his estate or if a trust deed be executed by him for benefit of his creditors.

(ix) If the contractor being a company shall pass a resolution or the court shall make an order that the company shall be wound up or if a receiver or a manager on behalf of a creditor shall be appointed or if circumstances shall arise which entitle the court or the creditor to appoint a receiver or a manager or which entitle the court to make a winding up order.

(x) If the contractor shall suffer an execution being levied on his goods and allow it to be continued for a period of 21 days.

(xi) If the contractor assigns (excluding part(s) of work assigned to other agency(s) by the contractor as per terms of contract), transfers, sublets (engagement of labor on a piece-work basis or of labor with materials not to be incorporated in the work, shall not be deemed to be subletting) or otherwise parts with or attempts to assign, transfer, sublet or otherwise parts with the entire works or any portion thereof without the prior written approval of the Engineer -in-Charge. When the contractor has made himself liable for action under any of the cases aforesaid, the Engineer-in-Charge on behalf of the President of India shall have powers:

(a) To determine the contract as aforesaid so far as performance of work by the Contractor is concerned (of which determination notice in writing to the contractor under the hand of the Engineer-in-Charge shall be conclusive evidence). Upon such determination, Security Deposit already recovered, Security deposit payable and Performance Guarantee under the contract shall be liable to be forfeited and shall be absolutely at the disposal of the Government

(b) After giving notice to the contractor to measure up the work of the contractor and to take such whole, or the balance or part thereof, as shall be un-executed out of his hands and to give it to another contractor to complete the work. The contractor, whose contract is determined as above, shall not be allowed to participate in the tendering process for the balance work including any new items needed to complete the work. In the event of above courses being adopted by the Engineer-in-Charge, the contractor shall have no claim to compensation for any loss sustained by him by reasons of his having purchased or procured any materials or entered into any engagements or made any advances on account or with a view to the execution of the work or the performance of the contract. And in case action is taken under any of the provision aforesaid, the contractor shall not be entitled to recover or be paid any sum for any work thereof or actually performed under this contract unless and until the Engineer-in-Charge has certified in writing the performance of such work and the value payable in respect thereof and he shall only be entitled to be paid the value so certified.

27. WORK TO BE EXECUTED IN ACCORDANCE WITH SPECIFICATIONS, DRAWINGS, ORDERS ETC.

The contractor shall execute the whole and every part of the work in the most substantial and workmanlike manner both as regards materials and otherwise in every respect in strict accordance with the specifications. The contractor shall also conform exactly, fully and faithfully to the design, drawings and instructions in writing in respect of the work signed by the Engineer-in-Charge and the contractor shall be furnished free of charge one copy of the contract documents together with specifications, designs, drawings and instructions as are not included in the standard specifications of Central Public Works Department specified in Bid or in any Bureau of Indian Standard or any other, published standard or code or, Schedule of Rates or any other printed publication referred to elsewhere in the contract.

The contractor shall comply with the provisions of the contract and with the care and diligence execute and maintain the works and provide all labor and materials, tools and plants including for measurements and supervision of all works, structural plans

and other things of temporary or permanent nature required for such execution and maintenance in so far as the necessity for providing these, is specified or is reasonably inferred from the contract. The Contractor shall take full responsibility for adequacy, suitability and safety of all the works and methods of construction.

28. DEVIATIONS/ VARIATIONS EXTENT AND PRICING

The Engineer-in-Charge shall have power

(i) to make alteration in, omissions from, additions to, or substitutions for the original specifications, drawings, designs and instructions that may appear to him to be necessary or advisable during the progress of the work, and

(ii) to omit a part of the works in case of non-availability of a portion of the site or for any other reasons and the contractor shall be bound to carry out the works in accordance with any instructions given to him in writing signed by the Engineer-in-Charge and such alterations, omissions, additions or substitutions shall form part of the contract as if originally provided therein and any altered, additional or substituted work which the contractor may be directed to do in the manner specified above as part of the works, shall be carried out by the contractor on the same conditions in all respects including price on which he agreed to do the main work except as hereinafter provided.

28.1 The time for completion of the works shall, in the event of any deviations resulting in additional cost over the tendered value sum being ordered, be extended, if requested by the contractor, as follows :

(i) In the proportion which the additional cost of the altered, additional or substituted work, bears to the original tendered value plus

(ii) 25% of the time calculated in (i) above or such further additional time as may be considered reasonable by the Engineer-in-Charge

28.2 In the case of extra item(s) (items that are completely new, and are in addition to the items contained in the contract), the contractor may within fifteen days of receipt of order or occurrence of the item(s) submit market rate claim rates, supported by proper analysis which shall include invoices, vouchers etc. and Manufacturer's specification for the work failing which the rate approved later by the Engineer-in-charge shall be binding and the Engineer-in-Charge shall within prescribed time limit of the receipt of the claims supported by analysis, after giving consideration to the analysis of the rates submitted by the contractor, determine the rates on the basis of the market rates and the contractor shall be paid in accordance with the rates so determined, failing which it will be deemed to have been approved.

28.3 In the case of contract items which exceed the limits laid down in bid, the contractor may within fifteen days of receipt of order or occurrence of the excess, claim revision of the rates, supported by proper analysis for the work in excess of the above mentioned limits, provided that if the rates so claimed are in excess of the rates specified in the schedule of quantities, the Engineer-in-Charge shall within prescribed time limit of receipt of the claims supported by analysis, after giving consideration to the analysis of the rates submitted by the contractor, determine the rates on the basis of the market rates (as per invoice, vouchers from the manufacturers or suppliers submitted by the agency and duly verified by Engineer in Charge or his representative) and the contractor shall be paid in accordance with the rates so determined. The prescribed time limit for finalizing rates for Extra Item(s) and Deviated Quantities of contract items is within 45 days after submission of proposal by the contractor without observation of the Engineer-in-Charge.

29. ACTION IN CASE WORK NOT DONE AS PER SPECIFICATIONS

All works under or in course of execution or executed in pursuance of the contract, shall at all times be open and accessible to the inspection and supervision of the

Engineer-in - charge, his authorized subordinates in charge of the work and all the superior officers, any of the organization engaged by the Institute for Quality Assurance and of the Chief Technical Examiner's Office, and the contractor shall, at all times, during the usual working hours and at all other times at which reasonable notice of the visit of such officers has been given to the contractor, either himself be present to receive orders and instructions or have a responsible agent duly accredited in writing, present for that purpose. Orders given to the Contractor's agent shall be considered to have the same force as if they had been given to the contractor himself. If it shall appear to the Engineer-in-charge or his authorized subordinates in charge of the work or the officers of the organization engaged by the Institute for Quality Assurance or to the Chief Technical Examiner or his subordinate officers, that any work has been executed with unsound, imperfect, or unskillful workmanship, or with materials or articles provided by him for the execution of the work which are unsound or of a quality inferior to that contracted or otherwise not in accordance with the contract, the contractor shall, on demand in writing which shall be made within twelve months of the completion of the work from the Engineer-in-Charge specifying the work, materials or articles complained of notwithstanding that the same may have been passed, certified and paid for forthwith rectify, or remove and reconstruct the work so specified in whole or in part, as the case may require or as the case may be, remove the materials or articles so specified and provide other proper and suitable materials or articles at his own charge and cost. In the event of failing to do so within a period specified by the Engineer-in- Charge in his demand aforesaid, then the contractor shall be liable to pay compensation at the same rate as under clause 30 of the contract (for non-completion of the work in time) for this default.

In such case the Engineer-in-Charge may not accept the item of work at the rates applicable under the contract but may accept such items at reduced rates as the authority specified in the bid may consider reasonable during the preparation of on account bills or final bill if the item is so acceptable without detriment to the safety and utility of the item and the structure or he may reject the work outright without any payment and/or get it and other connected and incidental items rectified, or removed and re-executed at the risk and cost of the contractor. Decision of the Engineer-in-Charge to be conveyed in writing in respect of the same will be final and binding on the contractor.

30. COMPENSATION FOR DELAY

If the contractor fails to maintain the required progress in terms of Clause 25 or to complete the work and clear the site on or before the contract or justified extended date of completion as per Clause 25 (excluding any extension under para 25.5) as well as any extension granted under Clause 28, he shall, without prejudice to any other right or remedy available under the law to the Government on account of such breach, pay as compensation the amount calculated at the rates stipulated below as the authority specified in bid may decide on the amount of accepted Tendered Value of the work for every completed day/ month (as determined) that the progress remains below that specified in Clause 25 or that the work remains incomplete.

(i) Compensation for delay of work

With maximum rate @ 1% (one percent) per month of delay to be computed on a per day basis based on the quantum of damage suffered due to stated delay on the part of the Contractor.

Provided always that the total amount of compensation for delay to be paid under this condition shall not exceed 10 % (ten percent) of the accepted Tendered Value of work or of the accepted Tendered Value of the Sectional part of work as mentioned in the bid for which a separate period of completion is originally given.

In case no compensation has been decided by the authority in bid during the progress of work, there shall be no waiver of right to levy compensation by the said authority if the work remains incomplete on the final justified extended date of completion. If the Engineer in Charge decides to give further extension of time allowing performance of work beyond the justified extended date, the contractor shall be liable to pay compensation for such extended period. If any variation in the amount of contract takes place during such an extended period beyond justified extended date and the contractor becomes entitled to additional time under Clause 28, the net period for such variation shall be accounted for while deciding the period for levy of compensation. However, during such further extended period beyond the justified extended period, if any delay occurs by events under sub Clause 25.2, the contractor shall be liable to pay compensation for such delay

Provided that compensation during the progress of work before the justified extended date of completion for delay under this clause shall be for non-achievement of sectional completion or part handing over of work on stipulated/justified extended date for such part work or if delay affects any other works/services. This is without prejudice to right of action by the Engineer in Charge under para 26 for delay in performance and claim of compensation under that clause.

In case action under Clause 30 has not been finalized and the work has been determined under Clause 26, the right of action under this clause shall remain post determination of contract but levy of compensation shall be for days the progress is behind the schedule on date of determination, as assessed by the authority in Schedule F, after due consideration of justified extension. The compensation for delay, if not decided before the determination of contract, shall be decided after the determination of contract.

The amount of compensation may be adjusted or set-off against any sum payable to the Contractor under this or any other contract with the Government. In case, the contractor does not achieve a particular milestone mentioned in the bid, or the re-scheduled milestone(s) in terms of Clause 25.4, the amount shown against that milestone shall be withheld, to be adjusted against the compensation levied as above. With-holding of this amount on failure to achieve a milestone, shall be automatic without any notice to the contractor. However, if the contractor catches up with the progress of work on the subsequent milestone(s), the withheld amount shall be released. In case the contractor fails to make up for the delay in subsequent milestone(s), the amount mentioned against each milestone missed subsequently also shall be withheld. However, no interest, whatsoever, shall be payable on such withheld amount.

Carrying out part work at risk & cost of Contractor

If contractor:

- (i) At any time makes default during currency of work or does not execute any part of the work with due diligence and continues to do so even after a notice in writing of 7 working days in this respect from the Engineer-in-Charge; or
- (ii) Commits default in complying with any of the terms and conditions of the contract and does not remedy it or takes effective steps to remedy it within 7 working days even after a notice in writing is given in that behalf by the Engineer-in-Charge; or Fails to complete the work(s) or items of work with individual dates of completion, on or before the date(s) so determined, and does not complete them within the period specified in the notice given in writing in that behalf by the Engineer-in-Charge.

(iii) The Engineer- in-Charge without invoking action under Clause 26 may, without prejudice to any other right or remedy against the contractor which have either accrued or accrue thereafter to Government, by a notice in writing to take the part work / part incomplete work of any item(s) out of his hands and shall have powers to :

(a) Take possession of the site and any materials, constructional plant, implements, stores, etc., thereon; and/or

(b) Carry out the part work / part incomplete work of any item(s) by any means at the risk and cost of the contractor.

The Engineer-in-Charge shall determine the amount, if any, is recoverable from the contractor for completion of the part work/ part incomplete work of any item(s) taken out of his hands and execute at the risk and cost of the contractor, the liability of contractor on account of loss or damage suffered by Government because of action under this clause shall not exceed 10% of the tendered value of the work.

In determining the amount, credit shall be given to the contractor with the value of work done in all respect in the same manner and at the same rate as if it had been carried out by the original contractor under the terms of his contract, the value of contractor's materials taken over and incorporated in the work and use of plant and machinery belonging to the contractor.

The certificate of the Engineer-in-Charge as to the value of work done shall be final and conclusive against the contractor provided that action under this clause shall only be taken after giving notice in writing to the contractor. Provided also that if the expenses incurred by the department are less than the amount payable to the contractor at his agreement rates, the difference shall not be payable to the contractor.

Any excess expenditure incurred or to be incurred by Government in completing the part work/ part incomplete work of any item(s) or the excess loss of damages suffered or may be suffered by Government as aforesaid after allowing such credit shall without prejudice to any other right or remedy available to Government in law or per as agreement be recovered from any money due to the contractor on any account, and if such money is insufficient, the contractor shall be called upon in writing and shall be liable to pay the same within 30 days.

If the contractor fails to pay the required sum within the aforesaid period of 30 days, the Engineer-in-Charge shall have the right to sell any or all of the contractors' unused materials, constructional plant, implements, temporary building at site etc. and adjust the proceeds of sale thereof towards the dues recoverable from the contractor under the contract and thereafter there remains any balance outstanding, it shall be recovered in accordance with the provisions of the contract.

In the event of above course being adopted by the Engineer-in-Charge, the contractor shall have no claim to compensation for any loss sustained by him by reason of his having purchased or procured any materials or entered into any engagements or made any advance on any account or with a view to the execution of the work or the performance of the contract

GENERAL RULES & DIRECTIONS:

Officer inviting tender	Chairman (EWD)
Engineer-in-Charge	Executive Engineer (Civil)
Accepting Authority	Chairman (EWD) with approval of Director, IIT Palakkad
Authority for fixing liquidated damages	Chairman, EWD

34. Settlement of Disputes & Arbitration

Except where otherwise provided in the contract, all questions and disputes relating to the meaning of the specifications, design, drawings and instructions here-in before mentioned and as to the quality of workmanship or materials used on the work or as to any other question, claim, right, matter or thing whatsoever in any way arising out of or relating to the contract, designs, drawings, specifications, estimates, instructions, orders or these conditions or otherwise concerning the works or the execution or failure to execute the same whether arising during the progress of the work or after the cancellation, termination, completion or abandonment thereof shall be dealt with as mentioned hereinafter:

I. If the contractor considers any work demanded of him to be outside the requirements of the contract, or disputes any drawings, record or decision given in writing by the Engineer-in-Charge or if the Engineer in Charge considers any act or decision of the contractor on any matter in connection with or arising out of the contract or carrying out of the work, to be unacceptable and is disputed, such party shall promptly within 15 days of the arising of the disputes request the Chairman (EWD), or where there is no Chairman (EWD) request the Director, IIT Palakkad who shall refer the disputes to Dispute Redressal Committee (DRC) within 15 days along with a list of disputes with amounts claimed if any in respect of each such dispute. The Dispute Redressal Committee (DRC) gave its decision within a period of 60 days extendable by 30 days by consent of both the parties from the receipt of reference from Chairman (EWD) / Director, IIT Palakkad. The constitution of the Dispute Redressal Committee (DRC) shall be as indicated in bid. Provided that no party shall be represented before the Dispute Redressal Committee by an advocate/legal counsel etc.

The DRC will submit its decision to the concerned Chairman (EWD) / Director, IIT Palakkad for acceptance. Chairman (EWD) in a time limit of 30 days from receipt of DRC decision will convey acceptance or other wise on the said decision .If the Dispute Redressal Committee (DRC) fails to give its decision within the aforesaid period or the Chairman (EWD) / Director, IIT Palakkad fails to give his decision in the aforesaid time limit or any party is dissatisfied with the decision of Dispute Redressal Committee (Chairman (EWD) the neither party may within a period of 30 days from the receipt of the decision of Dispute Redressal Committee (DRC), Chairman (EWD) / Director, IIT Palakkad or on expiry of aforesaid the time limits available to DRC / Chairman (EWD) / Director IIT Palakkad may give notice to the Chairman (EWD) / Director, IIT Palakkad for appointment of arbitrator on prescribed proforma as per Annexure - X under intimation to the other party.

It is a term of contract that each party invoking arbitration must exhaust the aforesaid mechanism of settlement of claims/disputes prior to invoking arbitration. Director, IIT Palakkad will be the authority for appointing arbitrators.

Director , IIT Palakkad shall in such case appoint the sole arbitrator as the case may be within 30 days of receipt of such a request and refer such disputes to arbitration.

It is a term of this contract that the party invoking arbitration shall give a list of disputes with amounts claimed, if any, in respect of each such dispute along with the notice for appointment of arbitrator and giving reference to the decision of the Chairman (EWD) / Director, IIT Palakkad on the finding / recommendation of DRC.

Parties, before or at the time of appointment of Sole arbitrator may agree in writing for fast track arbitration as per the Arbitration and Conciliation Act, 1996 (26 of 1996) as amended in 2015.

Subject to provision in the Arbitration and Conciliation Act, 1996 (26 of 1996) as amended in 2015 whereby the counter claims if any can be directly filed before the arbitrator without any requirement of reference by the appointing authority. The

arbitrator shall adjudicate on only such disputes as are referred to him by the appointing authority and give separate award against each dispute and claim referred to him and in all cases where the total amount of the claims by any party exceeds Rs. 1,00,000/-, the arbitrator shall give reasons for the award
The place of arbitration shall be Palakkad.

35. **WARRANTY** The bidder should offer the warranty period of minimum “**THREE YEARS**” for the manufactured Furniture. The security deposit will be withheld against the warranty period and the withheld amount will be released after completion of warranty period.

CHAIRMAN, EWD

Annexure 1
Schedule of Quantity

Name of Work: Furnishing of Materials Lab at Ground floor of C06, Sahyadri Campus.			
Item No	Description of Item	Quantity	Unit
1	<p>Supply and installation of a full steel Almirah, constructed using CRCA steel sheets with a thickness of 1.6 mm for both the body and the doors. All steel components are to undergo an acid wash and anti-corrosive treatment prior to the application of powder coating. The powder coating must be scratch-resistant, with a minimum thickness of 60 microns.</p> <p>The Almirah is to have the following specifications: Number of doors: 2 Number of shelves: 4 Height (excluding pedestal): 1855 mm Sheet thickness-1.6mm Width: 900 mm Depth: 480 mm Load-carrying capacity of each shelf: Minimum 300 kg, with necessary intermediate supports provided Construction type: Welded Pedestal height: 125 mm (clear) Finish color: Ash grey Handle and lock to be provided.</p>	8	each
2	<p>Supply and installation of Granite top Table with Storage Size 1500 mm x900mm x900mm Height as per the drawing no. Drawing no: IITPKD/EWD/MATERIALS-LAB/TABLE/01 Table Top :20mm thick Granite Under structure: 50 mm x50 mm x2.1 mm thick CR pipe for leg and support frame under the table top. Polyester powder coating with grade C matt finish as per IS 13871:1993. The DFT of the powder coating should not be less than 60 micron with approved brand. Worktop- Jet Black Granite. Bottom Storage unit is attached to the table frame Drawer unit with two drawers and two door unit made up of 18 gauge CRCA Sheet and drawers with center locking facility,full open type telescopic slide for drawers. Polyester powder coating with grade C matt finish as per IS 13871:1993. The DFT of the powder coating should not be less than 60 micron with approved brand. The drawer units are provided recessed handle and suitable lock. Storage Unit of size- 450 mm(L) x450mm(D) x600 mm (H)</p>	4	each
3	<p>Laboratory Stool: -Shape of stool - Square. Supported by 4-Legged Frame with Cross Supports on Top and Bottom. Frame Materials - made from 20 swg cold rolled square pipe with powder coating. Top material - 18mm rubber wood corners should be with beveled edges avoiding sharp corners. As per Drawing No: : IITPKD/EWD/MATERIALS-LAB/STOOL/02</p>	3	each

4	<p>Revolving Chair (Supply of Revolving chair of over all size:118.5 cm high ,58cm width with following specification and as per photo attached.Prefered makes are Fetaherlite,Transteeel and wipro, Godrej. Base:The 640 mm dia five pronged base shall be made out of nylon – Reinforced with bottom metal ribbing for additional buttress and strength. To conform ANSI/BIFMA X5.1-2011 General Purpose Office Chair Standards</p> <p>Castors:Castors - Twin Castors 50mm dia wheel made of Nylon castors conform to ANSI /BIFMA X 5.1 – 2002</p> <p>Seating Structure: Seat shall be made out of 12mm moulded hot pressed plywood in ergonomic shape fitted with high quality T - nuts and riveted in to the wood</p> <p>Upholstery: Cushion with high density cold cured self skinned pre moulded foam of 52 kg/cum density in the shape of plywood.</p> <p>Hardness -- 12.6kgf at 25%</p> <p>Synchro Mechanism:This mechanism manufactured out of cold Rolled Carbon Steel IS 513-1994 Sheets,The steel components shall be manufactured with highly precision tools for accuracy in matching other parts for smooth functioning. The steel components shall be fabricated by using Co2 welding process for giving uniform surface finish with higher tensile strength. Springs are made out of Grade II material. Composite release levers for locking mechanism & Gas lift height adjustment. The lever locks in upright and also in 17degree at maximum tilting position. Release lever mechanism for Locking and Gas lift height adjustment. The mechanism shall be lockable in zero (front) position</p> <p>Tension Control:Tension control shall be given below the side fixed with mechanism, Active, telescopic, rotating motion</p> <p>One Way Armrest: Moulded self skinning polyurethane arms confirming with steel inserts for long life and maintenance free usage. Using international styling moulded self skin, Polyurethane, metal inserts for durability, comfort and long life. PU Arms shall have density of 350 to 450 gm/ltr, for smooth finish aberration and scratch resistance and easy maintenance</p> <p>Back: Should have Mesh Back on Frames</p> <p>Fabric: Seat should be upholstered with approved fabric (Response Shade) which shall be Fire retardant & conform to BS EN 1021-1:1994 (Cigarette) BS 7176 : 1995 Low Hazard standards</p> <p>Seat:</p> <p>Depth-46 cm Width- 49.5 cm Maximum Height- HB: 118.5 cm; Minimum Seat Height- 45 cm Maximum Seat Height- 55.5 cm Width (Arm to Arm)- 46 cm Arm Rest Height- 62.5 cm" Weight capacity- 180 kg</p>	4	each
---	---	---	------

LIST OF APPROVED MAKES

Steel- TATA Steel, JINDAL Steel, SAIL

Powder Coating - Kansai Nerolac, Berger Paints, Asian Paints

Annexure IA

Granite top Table with Storage

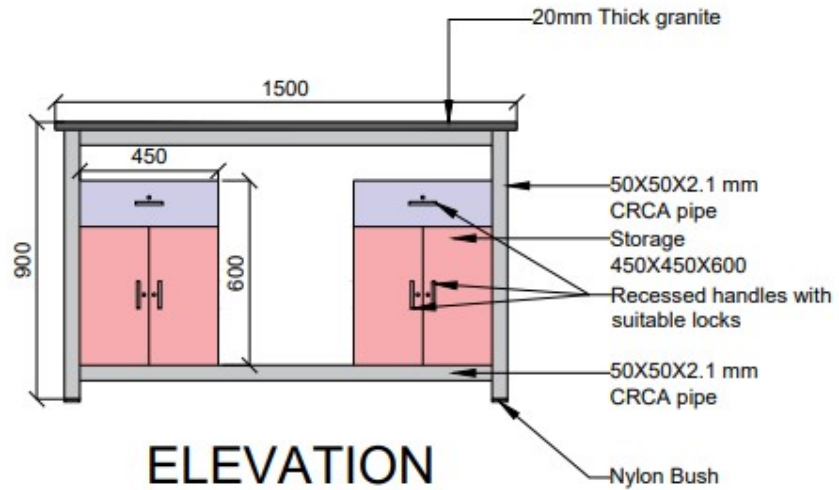

Laboratory Stool

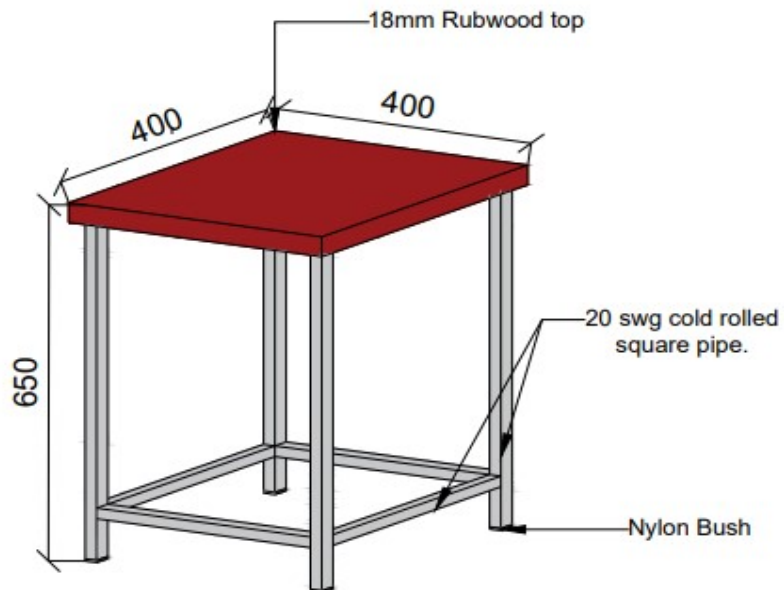

(Detailed Drawing attached separately in the E- wizard Portal)

Annexure II

ELIGIBILITY CRITERIA FOR BIDDERS

LIST OF DOCUMENTS TO BE SCANNED AND UPLOADED WITHIN THE PERIOD OF BID SUBMISSION

Only those bidders fulfilling the following criteria should respond to the tender.

1. Information related to the agency/bidder such as photocopies of the registration/PAN/GST/TIN shall be furnished.
2. Bidders, who are bidding for this shall have satisfactorily completed the works as mentioned below during the last **FIVE YEARS** ending previous day of last date of submission of bid:

THREE similar completed works each costing not less than the amount equal to

Rs. 1 lakh

(OR)

TWO similar completed works each costing not less than the amount equal to

Rs. 2 lakh

(OR)

ONE similar completed works each costing not less than the amount equal to

Rs. 3 lakh

“Cost of work” for this clause shall mean completed cost of work as mentioned in the final bill. However, the cost of materials issued free of cost shall not be considered for calculating the cost of work. The value of executed works shall be brought to current costing level by enhancing the actual value of work at a simple rate of 7% per annum; calculated from the date of completion to the last date of receipt of applications for bids. “Similar work” for this clause means "**Furniture & Fitting works.**"

3. Digitally signed tender documents should be uploaded in Cover One
4. Has the firm ever been debarred/blacklisted by any Govt. Organization/Dept.? If 'yes' the details thereof (Please upload supporting document). Is any person working with the applicant a near relative of the Employees of IIT Palakkad? If yes, give details (**Separate declaration to be uploaded along with tender document**)

ANNEXURE - III

LIST OF DOCUMENTS TO BE SCANNED AND UPLOADED WITH IN THE PERIOD OF BID SUBMISSION

1. Photocopies of the PAN/GST
2. GST registration Certificate of the Kerala State if already obtained by the bidder. If the bidder has not obtained GST registration of Kerala State as required by GST Authorities, then in such a case the bidder shall scan and upload the following undertaking along with other bid documents.
"If work is awarded to me, I/We shall obtain GST registration certificate of the Kerala State, within one month from the date of receipt of award letter or before release of any payment by IITPKD, whichever is earlier, failing which I/We shall be responsible for any delay in payments which will be due towards me/us on a/c of the work executed and/or for any action taken by IITPKD or GST Department in this regard".
3. Details of All Works of Similar Nature Completed during The Last Five Years - FORM A
4. Performance Report for similar works completed - FORM B
5. Letters of Transmittal
6. Digitally signed tender document

Annexure-IV
FORM OF PERFORMANCE SECURITY
BANK GUARANTEE BOND

In consideration of the Indian Institute of Technology Palakkad (hereinafter called "IIT Palakkad") having offered to accept the terms and conditions of the proposed agreement between.....and.....
(hereinafter called "the said contractors") for the work(hereinafter called "the said agreement") having agreed to production of a irrevocable Bank Guarantee for Rs.....
(Rupees.....only) as a security /guarantee from the contractor(s) for compliance of his obligations in accordance with the terms and conditions in the said agreement.

1. We..... (Hereinafter referred to as "the
(Indicate the name of the Bank)

Bank") hereby undertake to pay to the IIT Palakkad an amount not exceeding Rs..... (Rupees.....only) on demand by the IIT Palakkad.

2. We(Indicate the name of the Bank) do hereby undertake to pay the amounts due and payable under this Guarantee without any demure, merely on a demand from the IIT Palakkad stating that the amount claimed is required to meet the recoveries due or likely to be due from the said contractors. Any such demand made on the Bank shall be conclusive as regards the amount due and payable by the Bank under this Guarantee. However, our liability under this guarantee shall be restricted to an amount not exceeding Rs..... (Rupees.....only).

3. We, the said Bank further undertake to pay to the IIT Palakkad any money so demanded notwithstanding any dispute or disputes raised by the contractors in any suit or proceeding pending before any Court or Tribunal relating thereto, our liability under this present being absolute and unequivocal. The payment made by us under this bond shall be a valid discharge of our liability for payment there under and the contractors shall have no claim against us for making such payment.

4. We.....(indicate the name of the Bank) further agree that the guarantee herein contained shall remain in full force and effect during the period that would be taken for the performance of the said agreement and that it shall continue to be enforceable till all the dues of the IIT Palakkad under or by virtue of the said agreement have been fully paid and its claims satisfied or discharged or till Engineer-in-Charge on behalf of the government certified that the terms and conditions of the said agreement have been fully and properly carried out by the said contractors and accordingly discharges this guarantee.

5. We(Indicate the name of the Bank) further agree with the Government that the IIT Palakkad shall have the fullest liberty without our consent and without effecting in any manner our obligations hereunder to vary any of the terms and conditions of the said agreement or to extend time of performance by the said contractors from time to time or to postpone for any time or from time to time any of the powers exercisable by the Government against the said contractors and to for-bear or enforce any of the terms and conditions relating to the said agreement and we shall not be relieved from our liability by reason of any such variation or extension being granted to the said contractors or for any forbearance, act of omission on the part of the Government or any indulgence by the Government to the said contractor(s) or by any such matter or thing whatsoever which under the law relating to sureties would, but for this provision have effect of so relieving us.

6. This guarantee will not be discharged due to the change in the constitution of the Bank or the contractor(s).

7. We (Indicate the name of the Bank) lastly undertake not to revoke this guarantee except with the previous consent of the Government in writing.

8. This guarantee shall be valid up to _____ unless extended on demand by IIT Palakkad. Notwithstanding anything mentioned above, our liability against this guarantee is restricted to Rs. _____ (Rupees _____ only) and unless a claim in writing is lodged with within six months of the date of expiry or the extended date of expiry of this guarantee all our liabilities under this guarantee shall stand discharged.

Dated the _____ day of _____ for _____

(Indicate the name of the Bank).

ANNEXURE-V

DECLARATION

We hereby undertake that there are _____ pages, serially numbered, in the submitted tender including the supporting documents. (Please serial number all the pages including blank pages, if any). We have submitted our principal's exclusive authorization letter which is specific for this tender No. _____ dated _____.

Signature and Seal of the Bidder

ANNEXURE-VI

FALL CLAUSE NOTICE CERTIFICATE

(To Be Submitted Only Through Online Mode in Appropriate Format)

This is to certify that we have offered the maximum possible discount to you in our Quotation No._dated_(Please do not reveal the prices here, which will lead to outright rejection of your bid). The prices charged for the Stores supplied under tender should under no event be higher than lowest prices at which the party sells the items of identical description to any other Govt. organization/PSU"s/Central Govt, /State Govt. Autonomous bodies/Central/state Universities/Central/State Educational Institutions, failing which the "FALL CLAUSE" will be applicable. The institute will look into a reasonable past period to ensure this. In case, if the price charged by our firm is found to be more, IIT Palakkad will have the right to recover the excess charged amount from the subsequent/unpaid bill of the Contractor.

Note:

This letter of authority should be on the letterhead of the quoting firm and should be signed by a Competent Authority and having the power of attorney.

LETTER OF TRANSMITTAL

(To be duly filled, signed, scanned and uploaded along with e-cover 1 by the tenderer)

To

The Chairman, EWD

IIT Palakkad

Sir,

Having examined the details given in notice inviting qualification application and tender and the qualification documents for the above work, I / We hereby submit the application for eligibility and the tender (financial bid) for the work duly filled in.

1. I / We hereby certify that all the statements made, and information supplied in the enclosed forms and accompanying statements are true and correct.
2. I/ We have furnished all information and details necessary for deciding our eligibility to be qualified for taking part in the tendering process for the work. We have no further information to supply.
3. I / We submit the requisite solvency certificate and authorize the CHAIRMAN EWD, Engineering Works Department, EWD to approach the bank concerned to confirm the correctness of the certificate. We also authorize the CHAIRMAN, EWD to approach individuals, firms and corporations to verify our competence and general reputation.
4. I/We submit the following certificates in support of our suitability, technical know-how and capability for having successfully completed following works.

Name of work

Certificate from

5. I/We certify that the tender documents uploaded is the exact replica of the document published by the IITPKD and no alterations and additions have been made by me/us in the e- tender document.
6. I am /We are aware that the Financial bid submitted by me/us will not be opened if I/We do not become eligible after evaluation of my/our application for eligibility.
7. I/We certify that the Proforma for EMD Declaration and Bank guarantee which was /were scanned and uploaded while submitting the e- Wizard.
8. I/we agree that the eligibility criteria submissions will become part of the contract.

Seal of the Applicant

Date of submission

Signature(s) of the applicants

Annexure -

FORMAT OF UNDERTAKING, TO BE FURNISHED ON COMPANY LETTER HEAD WITH REGARD TO BLACKLISTING/ NON- DEBARMENT, BY ORGANISATION

UNDERTAKING REGARDING BLACKLISTING / NON – DEBARMENT

We hereby confirm and declare that we, M/s -----, is not blacklisted/ De-registered/ debarred by any Government department/ Public Sector Undertaking/ Private Sector/ or any other agency for which we have Executed/ Undertaken the works/ Services

For -----

Authorized Signatory

Date:

Form A

(To be duly filled, signed, scanned and uploaded along with cover 1 by the tenderer)
DETAILS OF ALL WORKS OF SIMILAR NATURE COMPLETED DURING THE LAST
FIVE YEARS.

Sl No	Name of work Project / Location	Owner or organizations	Agreement Scope of work*	Cost of Date of Work in Commencement	Stipulated Date of completion	Actual date of completion

Signature of Applicant(s)

In case of works carried out for private persons/ Organizations copies TDS certificate along with copy of performance order and work order/Agreement should be enclosed. Private works without TDS certificates shall not be considered for eligibility.

Form B

(To be duly filled, signed, scanned and uploaded along with cover 1 by the tenderer)

PERFORMANCE REPORT FOR WORKS REFERRED

I. Name of the work/Project & Location.

1. Scope of work.

2. Agreement No.

3. Estimated Cost

4. Tendered Cost

5. Value of work done

6. Date of Start

7. Date of completion

8. Amount of compensation levied for deficiency in services if any.

9. Performance report based
on Quality of Work,
Time Management,
and Resourcefulness

: Very Good /Good /Fair / Poor

DATE:

EXECUTIVE ENGINEER/ PROJECT MANAGER OR
EQUIVALENT

Certificate shall be submitted separately for each work